



RESIDENTIAL

Air Conditioners



KANION™

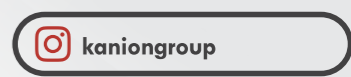

kanionco.com

what if

every home underwent a revolutionary change, embracing both ecological consciousness and unparalleled comfort.

WHAT IF KANION CO...





6	Kanion Co
9	Social Responsibility
10	Chronicle of Development
12	Internationally Reliable Brand
14	R&D Strength
26	Global Prosenace
28	Series Introduction
30	Category Coverage
32	Products
	- Origin
	- Deluxe
	- Rex
	- Premium
	- Aeolus
	- Solar Air Conditioner

C O N T E N T S

KANION CO



Founded in 2010, Kanion Co has grown into a global brand. Through continuous innovation and an unwavering commitment to sustainability, Kanion Co has been established as a sheer trendsetter in developing eco-friendly, energy-efficient air conditioning solutions without compromising indoor comforts.

Pioneering Eco-Conscious Solutions

Kanion Co's has been founded on the premise of pushing boundaries and challenging conventions. With significant investments in R&D, materials science, and next-generation manufacturing processes, Kanion Co delivers advanced products that set new standards of performance, efficiency, and sustainability. The group's highly skilled team relentlessly researches for innovative ways to maximize cooling power while minimizing energy use and environmental footprint.

Kanion Co's mission transcends manufacturing best-in-class air conditioners that incorporate recyclable and non-toxic materials, minimize waste, and prioritize energy conservation in all operations. The final goal is to provide reliable comfort and promoting responsible energy use for households and businesses worldwide.

Integrating Clean Energy Resources

Sustainability today translates to so many more initiatives than just reducing energy consumption - it's truly about reimagining climate solutions.

Kanion Co products go beyond energy efficiency by integrating solar technologies. This seamless initiative taps into renewable solar energy to drastically reduce reliance on fossil fuels and move closer to achieving net-zero energy usage.

The initiative doesn't stop there. In a journey to constantly innovate, Kanion Co strives to maximize energy conservation at every touchpoint. This can be further broken down in eco-friendly refrigerants, recyclable materials, optimized heat transfer systems to minimize the carbon footprint, products that utilize energy waste to cover our most demanding and energy consuming domestic needs and Total Energy Solution with an array of advanced energy storages and inverters that can integrate with all our products.

Kanion Co vision is to spearhead the transition to a cleaner energy planet, today, not tomorrow, so as to be able to preserve our environment for generations to come. With every new product, this goal seems to be turning from a dream, to a plan.

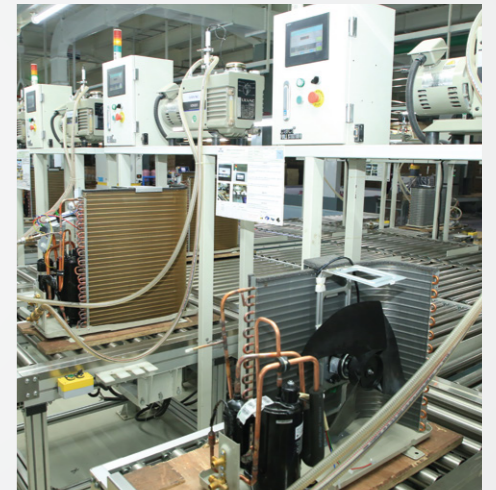

Recognitions & Accolades

Most recently, in 2023 - 2024, Kanion Co was featured among the most environmentally friendly companies worldwide in a special issue by The CEO Magazine®, an affirmation to our efforts of developing eco-conscious air conditioning solutions that reduce energy consumption and carbon footprint, while the Co was also named Best Air Conditioner Supplier by the Corporate Vision Magazine® for unrivalled product quality and performance and was included in the 50 Best Companies in the World to Watch by The Silicon Review®, for continuous advancements in air conditioning technology through investments in R&D and sustainability.

Looking ahead, Kanion Co remains committed to innovating, leading, and pushing the envelope when it comes to sustainable air conditioning and continuing developing cutting-edge solutions that set the global standard for efficiency, effectiveness, and eco-consciousness.

Worldwide Presence

Kanion Co products meet the unique requirements of almost every country. Meticulously designed to adhere to different import, certification, safety, and environmental standards, Kanion Co air conditioners are available across the globe, each tailored to meet the bespoke needs of our diverse customer base.

Our product range not only meets varied capacity requirements but is also equipped with cutting-edge technology to ensure optimal performance in extreme climates. From the sub-zero temperatures in the farthest reaches of the North and South to the humidity and high temperatures of equatorial regions, Kanion Co air conditioners are built to perform.

Kanion Co combines global reach, robust manufacturing processes, and state-of-the-art production bases to deliver world-class air conditioning solutions.

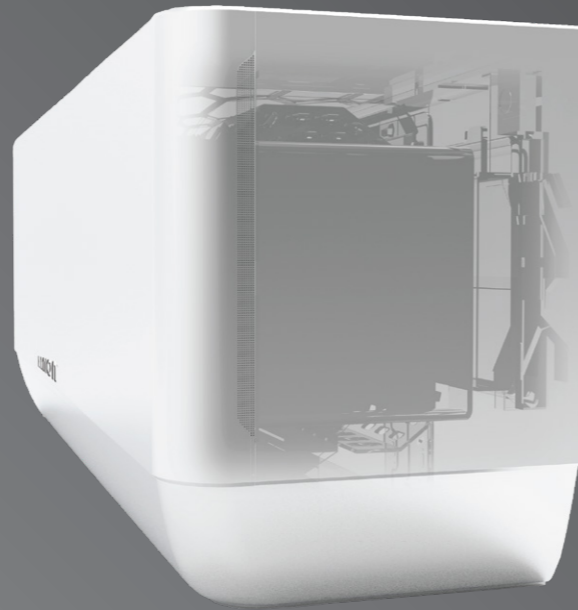

Manufacturing Philosophy

At Kanion Co we subscribe to the belief that well-designed processes can minimize the potential for human error, thereby increasing robustness. Our approach to process robustness is divided into three key stages:

Critical Quality Attributes (CQA): These are the key features we strive to instill in our final products, including purity, technological innovation, efficiency, environmental friendliness, and safety.

Critical Process Parameters (CPP): In this stage, we define and set crucial elements like raw materials, manufacturing equipment, and the degree of automation to ensure adequate control.

Setting Tolerance Limits: Here, we establish upper and lower tolerance limits to define acceptable quality levels, thereby ensuring the production of superior final products.



Production Facilities

Xiaolan Air Conditioners Production Base

Boasting an area of 20,000 square meters, this production base houses 4 production lines manned by over 1,000 employees. Commercial air conditioners produced here are exported to more than 100 countries.

100K+
Square Meters
Production Base Area

Beijiao Air Conditioners Production Base

This production base covers an area of 38,000 square meters, featuring 5 production lines with over 1,000 employees. Residential air conditioners produced here, including wall split mounted types, window types, portable types, floor standing types, and dehumidifiers, are exported to over 100 countries.

14+
Different International
Certificate

Kanion Co Head Office

The head office of Kanion Co's China mainland company is situated in the Luohu District, the business center of Shenzhen. The transportation is convenient, about 30km to Shenzhen International Airport, about 50km to Hong Kong International Airport, and about 25km to Shenzhen Yantian Port and Shekou Port.

25+
Different Air Conditioning
Products Available In Variable
Capacities

SOCIAL RESPONSIBILITY

At Kanion Co social responsibility equals commitment to people and the planet. Eco-conscious culture starts at home and as Kanion Co products step into an increasing number of homes globally, we do feel our part in the common effort gets more important by the day.



K-Climate Hub Initiative

A free, online, global platform dedicated to sharing tools of measuring a home's energy consumption and environmental footprint and tips and consistent knowledge on how to improve energy efficiency, properly use home appliances, and adopt a greener lifestyle with minimum effort and time invested. The K-Climate Hub provides actionable tips that anyone can daily implement.

Utilizing Existing Media

Regularly shooting videos of educative nature, giving the chance to the general crowd to become ambassadors of sustainability and the planet's conservation.

"what if" Innovation Policy

Encouraging an open exchange of ideas by welcoming anyone at all levels to suggest innovations through the "What If" program, in the hopes of fostering a culture of creativity and engagement and result in continuously improving products and practices. Long story made short, everybody is encouraged to suggest dual benefits of indoor and outdoor energy conservation (more information to follow on K-Climate Hub soon...)

Waste Segregation

Implementing waste segregation across all our premises to eliminate garbage headed to landfills. All our associates are committed to properly separating trash for recycling and composting.

CHRONICLE OF DEVELOPMENT

Kanion Co has charted a remarkable journey since its establishment in 2010. From its humble beginnings, the Co has grown into a prominent player in the air conditioning industry. Let's take a closer look at the significant milestones in the Co's timeline:



Air Conditioning division Kanion products are accredited some of the most prestigious and demanding certificates globally.

The Silicon Review®



Awarded by Silicon Review and Corporate Vision Magazine among the most prestigious start-ups globally.



360 Energy Hub is established and inverters, energy storages and Air To Water Heat Pumps are introduced in to the Co's portfolio.

2010

2016

2018

Solar air conditioning division is established and conventional air conditioners are regularly integrated with solar technologies.



2022

2023

Kanion Co products hold the Eurovent, BAFA and the SG Ready certification, further highlighting their reliability and adherence to industry standards.



2024

2023

Invited by The CEO Magazine to exhibit the Co's approach on sustainability and develop a discussion of broader interest on the matter.



2025

Launch of K-Mind AI — the brilliant, totally free brain that's about to revolutionize how the world designs, installs and lives with all HVAC products and energy efficiency. Ask it anything from R32 refrigerant details to full system proposals and watch it deliver perfect answers in seconds, no subscriptions, no catch. The future of smart HVAC just went open-source.



2026

k-climate hub

K-Climate Hub initiative is established. A free, online, global platform dedicated to sharing tools of measuring a home's energy consumption and environmental footprint and tips and consistent knowledge on how to improve energy efficiency.

INTERNATIONALLY RELIABLE BRAND

Kanion Co takes great pride in producing products that adhere to rigorous regulations and certification standards set by various countries and organizations. Our commitment to quality and compliance ensures that our customers can trust in the reliability and safety of our air conditioning solutions. In fact, many of our products have received accreditation for government rebates in North America, Europe, and other regions worldwide. This recognition further demonstrates the superior performance and energy efficiency of Kanion Co's offerings, making them a smart choice for both consumers and businesses seeking top-notch air conditioning solutions.



CB



CE



RoHS

R&D Strength

Significant Features



COP / EER

What are the COP and EER indexes on home appliances energy labels?

COP stands for Coefficient of Performance, and EER stands for Energy Efficiency Ratio. Both COP and EER are metrics used globally to measure the efficiency of cooling systems, including air conditioners.

Why is it so important to know the COP and EER indexes of our home appliances?

Because higher values of COP and EER indicate greater energy efficiency and lower operating costs. Also the date of COP and EER is relevant because efficiency standards and technologies can change over time, so newer units may have more advanced and efficient performance.

It is advisable to check the date of COP and EER information to ensure that we have the most up-to-date and accurate efficiency ratings when comparing different air conditioning units. This helps us make informed decisions based on the latest industry standards and technological advancements.

For more 360 approach on the subject stay tuned with Kanion Co's online initiative "K – Climate Hub: <https://kclimatehub.com/>" to be launched soon.

A Story of Exceeding the Standards

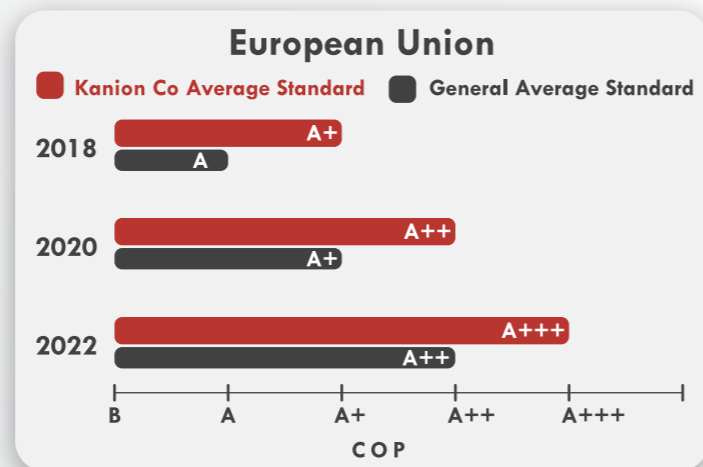
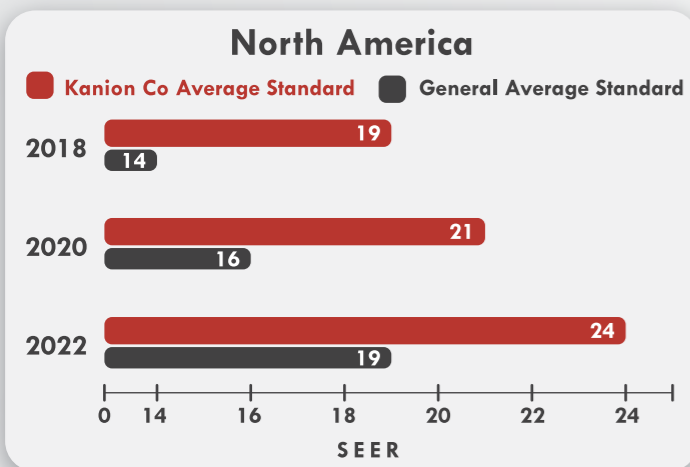

* Kanion Co products constantly exceed the Average Energy Efficiency Standards of North America and European Union for mini split air conditioners and heat pumps.

SOURCE: KANION CO ARCHIVES

Advanced Conception

INDOOR UNIT

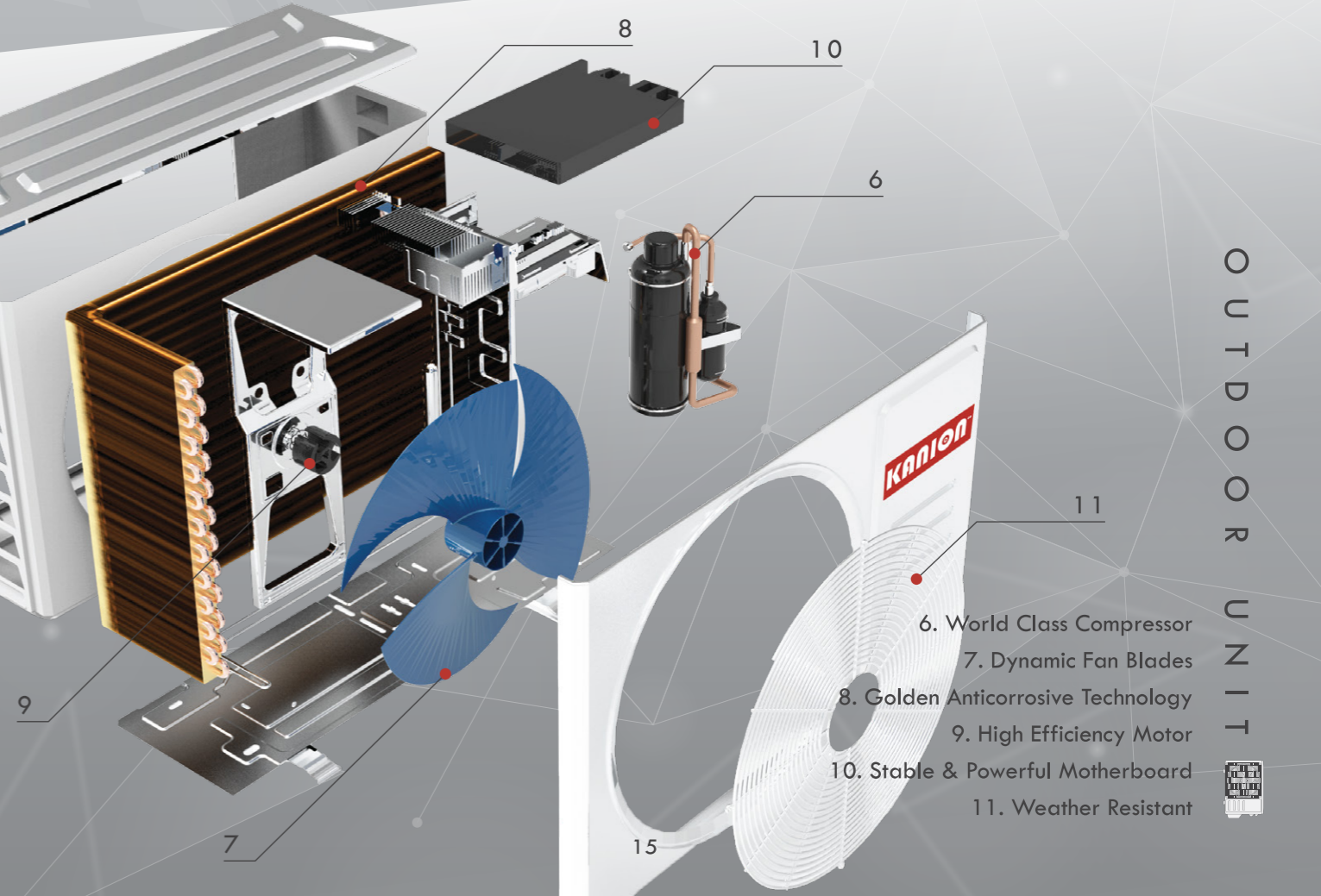
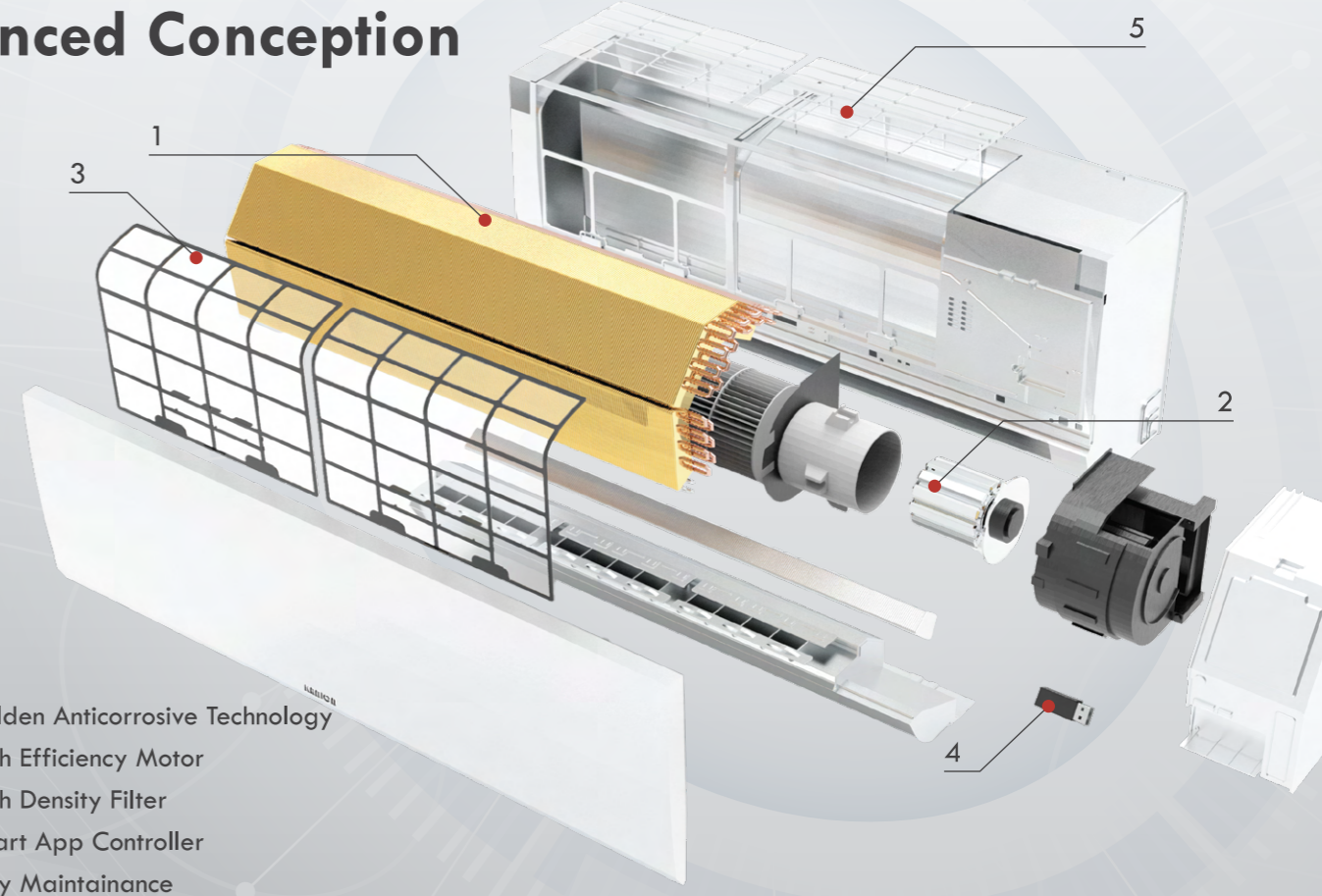

OUTDOOR UNIT



3D DC Inverter Technology

Inverter compressor provides powerful heating and cooling with minimum power consumption while inverter indoor and outdoor motors deliver comfortable airflow with maximum efficiency.



Integration with Solar Technologies

Kanion Co Air Conditioners are integrated with the latest solar technologies, such as Energy Storage Devices and solar panels and are available in two types that cover the global needs for renewable energy, Hybrid solar air conditioners that work both on solar & grid power and 100% solar.

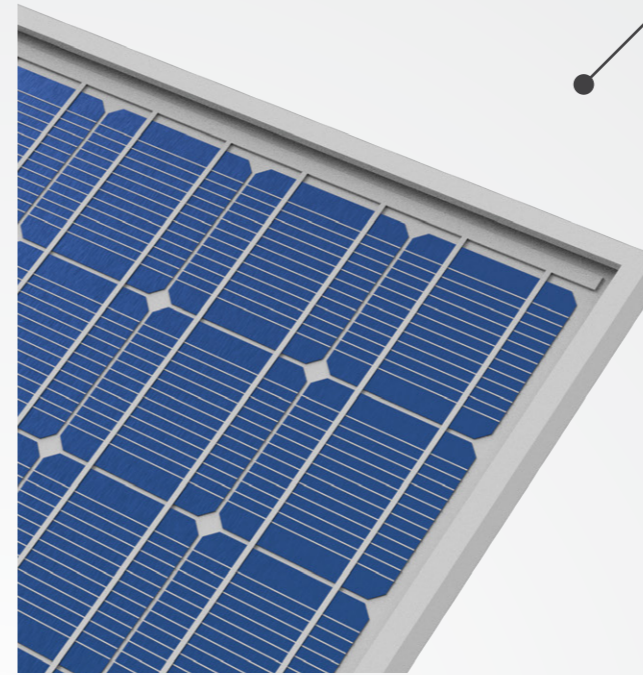

Hybrid Solar

Cost savings
Reduced emissions
Operational flexibility
Grid independence
Simple installation and operation

100% Solar

Zero emissions
Grid independence
Maximum savings
Simple design
Maximum sustainability



Smart Features

Smart App Controller

The control of your air conditioner is in the reach of your hand; The APPs Kanion Solar, K-Deluxe and K-Premium are available for free downloading and use on Google Play Store™ & App Store™.



Kanion Solar



K-Deluxe



K-Premium

Works with Smart Speakers

Kanion Co air conditioners equipped with Smart App Controller work with all the major A.I. Voice Assistants, promoting and enhancing your smart home experience.



Smart Sleep Mode

Smart sleep mode with photosensitive display.

Smart Air Flow

The air conditioner senses human presence and sets the air flow to follow people in the room.

Energy Consumption Management



Filters & Additional Air Health Functions

Kanion Co Air Conditioners are available with 6 different filter types that completely cover increased needs for healthy air.

- BIO FILTER
- VITAMIN C FILTER
- ACTIVE CARBON FILTER
- COLD CATALYST FILTER
- SILVER ION FILTER
- NANO TiO2 FILTER

And three new bacteria and viruses elimination technologies.

Bipolar Ionic Generator

UVC Sterilization Pro

56°C High Temperature Self-cleaning & Sterilization

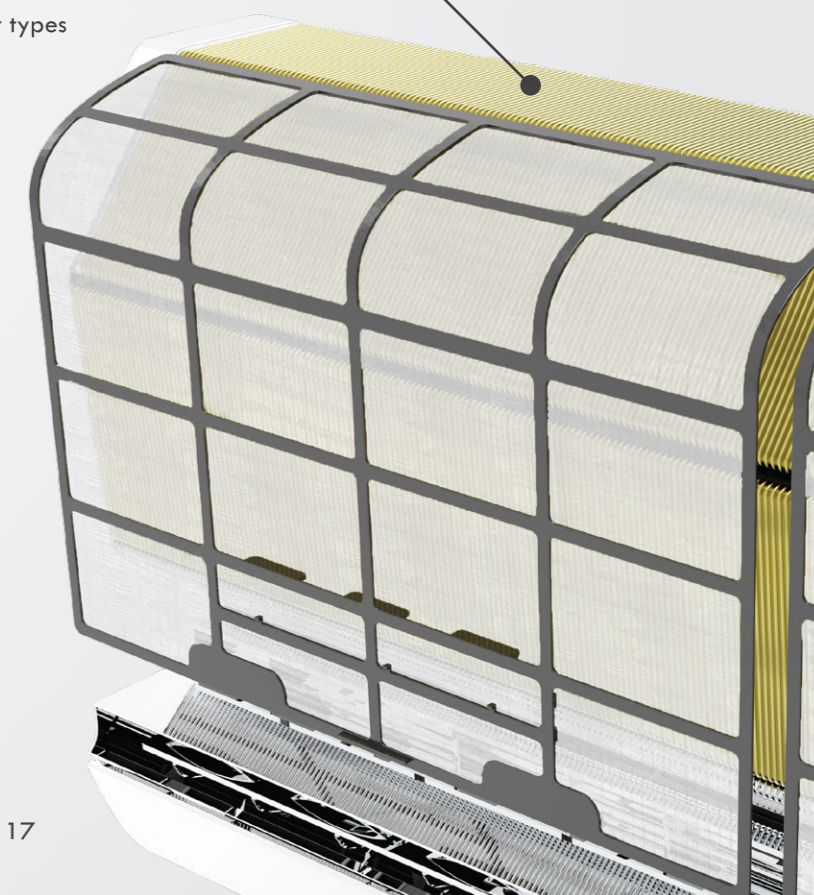

WORLD CLASS COMPRESSOR

Engineered with precision and advanced technology, Kanion Co's compressors set the standard for excellence in the industry.



STABLE & POWERFUL MOTHERBOARD

At the heart of Kanion Co air conditioners lie a stable and powerful motherboard. Intelligently engineered, ensures the smooth and efficient functioning of the entire system. Its robust design guarantees stability, reliability, and long-term performance.

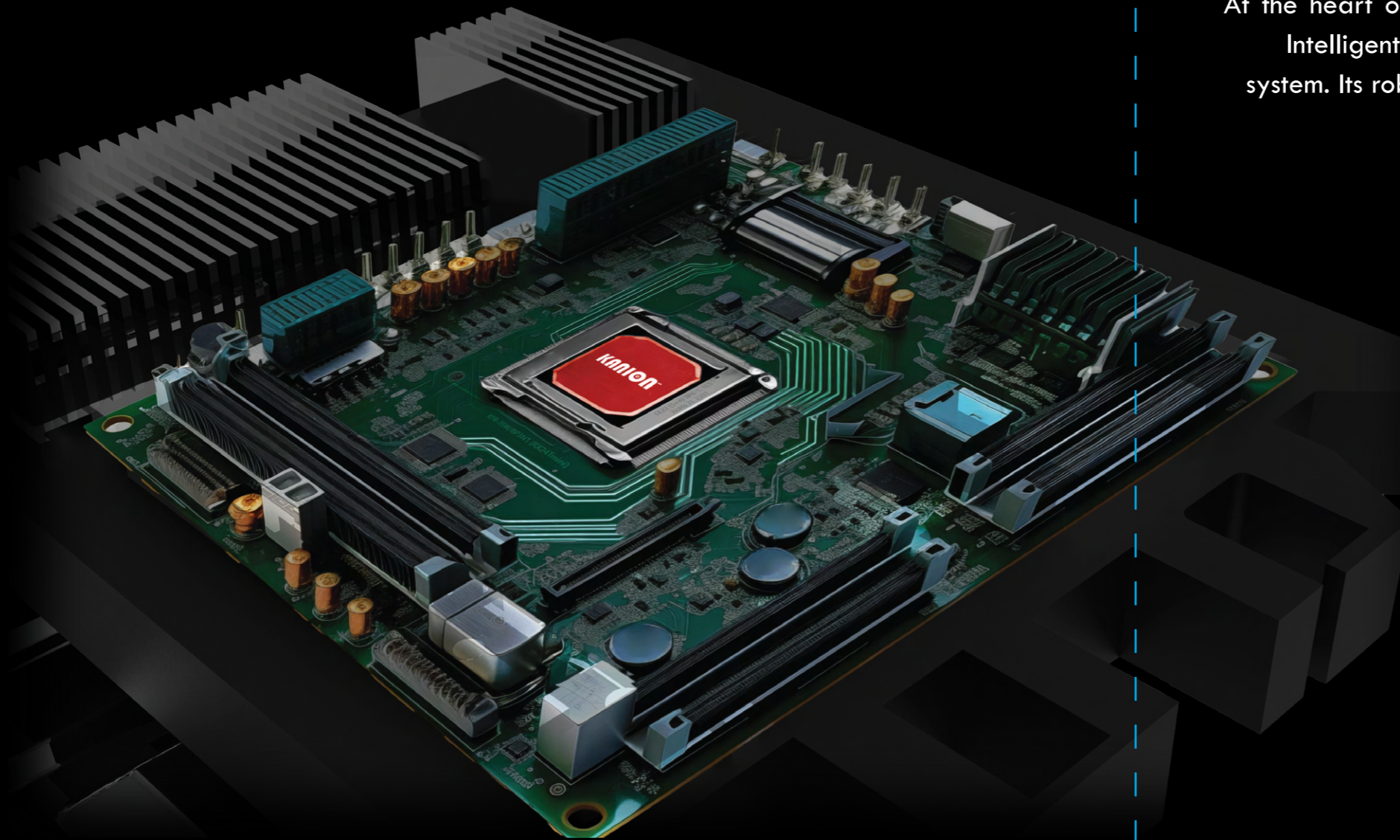

HIGH EFFICIENCY **MOTOR**

Delivering outstanding performance while minimizing energy consumption, Kanion Co motors are meticulously designed to optimize airflow and enhance efficiency.





ENERGY CONSUMPTION MANAGEMENT

With Energy Consumption Management (ECM), you observe in real time the power consumed by your air conditioner, while you are further enabled to pre-set the desired consumption level or be allowed to figure out and stick with the most environmentally friendly consumption behaviors.

*(ECM) is a function of the smart app controller



Global Presence

75+

Countries

Distribution Per Region

North America: 30%

Europe: 25%

Africa: 20%

South America: 15%

Middle East: 4%

Asia: 3%

Asia Pacific: 3%



Series Introduction



Kanion Co air conditioners are available in five distinct series: Origin, Deluxe, Rex, Premium and Aeolus. Regardless of the series one can rest assured in the Co's unwavering commitment to excellence, innovation, and customer satisfaction.

Common Features

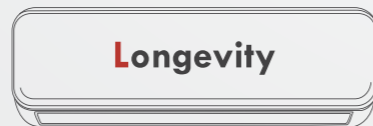

PERFECTLY ATTUNED 360 ORIGIN series



Origin Series stands as a titan of versatility and excellence, commanding attention with its comprehensive capabilities that cover every angle with finesse. Origin series meeting and exceeding expectations across all fronts but also perfectly attuned to the unique needs of North American and European climates.



ENERGY EFFICIENCY DELUXE series



Deluxe series is designed to minimize the environmental footprint of air conditioner usage and adheres to the most rigorous and demanding safety and environmental certificates globally. With worldwide availability, mainly caters for North America and Europe.



SMART COMPATIBILITY Rex Series

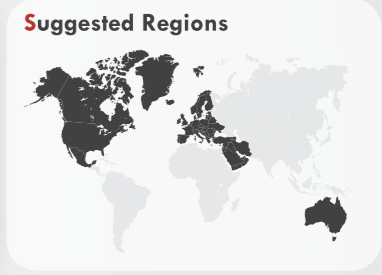

Rex Series embodies the most advanced smart features both from a user's friendly viewpoint as well as from health's perspective, combined with a very environmentally friendly technology. With worldwide availability it mainly caters for technologically affiliated and health-conscious audiences.



AFFORDABILITY premium series



Premium Series means value for money. With budget prices it offers a pool of amazing smart features combined with a very potent inverter technology. Available and popular globally.



EXTREME CONDITIONS AEOLUS series

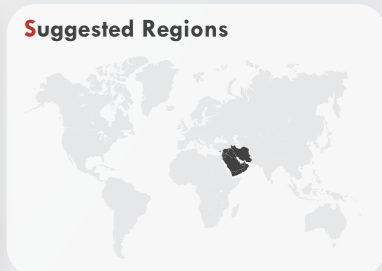

Aeolus Series is designed for extreme conditions, the epitome of reliability, durability, and optimal comfort. With worldwide availability, mainly caters for Middle East and near the equator regions.

Category Coverage



Fixed Frequency Wall Split Air Conditioner

Reliability and affordability with Kanion Co fixed frequency air conditioners that provide a cost-effective cooling and heating solution for every space.



Inverter Wall Split Air Conditioner

Environmentally friendly choice that saves energy and reduces utility bills. With advanced variable compressors, Kanion Co Inverters consume significantly less power while maintaining optimal comfort.

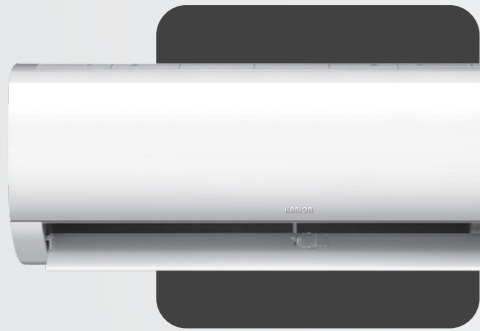

DIY Wall Split Air Conditioner

Equipped with pre-charged line sets, Kanion Co DIY can be easily installed by anyone. Say goodbye to high installation costs and hello to a greener, energy-efficient cooling and heating solution.



Solar Wall Split Air Conditioner

Available in hybrid and 100% off-grid, Kanion Co Solar helps reduce your utility bills to zero or near-zero while minimizing your household's carbon footprint. Embrace sheer sustainability and protect our planet.

Portable / Mobile Air Conditioner

Ideal for small apartments or spaces where split air conditioners are not feasible, Kanion Co portable offers effective cooling and heating with a low environmental footprint. Enjoy hassle-free installation and easy operation.



Window / Room Air Conditioner

Designed for small apartments, student dormitories, or spaces where split air conditioners are not suitable, Kanion Co Window offers effective temperature control with minimal impact on the environment. Experience simplicity and comfort in one unit.



Floor Standing Air Conditioner

These big-sized split units offer high capacity, ensuring optimal comfort even in expansive areas. Enjoy easy installation and maintenance with a floor-mounted design.



Dehumidifier

Kanion Co dehumidifiers help regulate humidity levels, preventing mold, mildew, and other moisture-related issues. Experience a balanced indoor atmosphere for enhanced well-being and peace of mind.



ORIGIN

series
ORIGIN



Origin Story

5000 years ago, a cataclysmic surge of geothermal activity erupted from the depths of the Earth. Amidst this chaos, Origin is a time-traveler with the power to command heat and cold. Foreseeing the planet's peril, Origin descended upon Earth, quelling the volcanic turmoil and averting disaster. Once the crisis had passed, Origin departed, fading into the annals of history to become a legend of myth and lore. Some revered Origin as a deity of old, while others dismissed the tale as mere fantasy.

Yet, the true identity and purpose of Origin remained shrouded in mystery, a puzzle unsolved through the ages. What connection did Origin share with its modern counterparts—Deluxe, Rex, Premium, and Aeolus? The threads of fate intertwined, weaving a tapestry of unknown destinies waiting to be unraveled.

To be continued...

SEER2 21.0 - 22.0 3D DC Inverter Wall Split Air Conditioner KO2



Model number	KWSM-09IR32HS22LO	KWSM-12IR32HS21.5LO	KWSM-09IR32HS22O	KWSM-12IR32HS21.5O		
Power supply	115V / 1Ph / 60Hz		208 - 230V / 1Ph / 60Hz			
Heat exchangers	Highly Anti-corrosive Coating on Heat Exchangers / Best efficiency option					
Capacity	Btu / h	9000	12000	9000	12000	
SEER2		22.0	21.5	22.0	21.5	
Control type	Remote Controller & Smart App Controller compatible with all major A.I. voice assistants (Standard) / Wire Thermostat Control (Optional)					
Refrigerant type	R32 Environmentally Friendly Refrigerant					
Compressor	Frequency	3D DC Inverter Technology				
Operation temperature	°C	16 ~ 30				
Applicable area	Sq.ft	129.17 - 193.75	172.22 - 258.33	129.17 - 193.75	172.22 - 258.33	
Loading quantity	40'HC	Set	258	286	258	286

Model number	KWSM-18IR32HS21.5O	KWSM-24IR32HS22O	KWSM-36IR32HS21O		
Power supply	208 - 230V / 1Ph / 60Hz				
Heat exchangers	Highly Anti-corrosive Coating on Heat Exchangers / Best efficiency option				
Capacity	Btu / h	18000	24000	36000	
SEER2		21.5	22.0	21.0	
Control type	Remote Controller & Smart App Controller compatible with all major A.I. voice assistants (Standard) / Wire Thermostat Control (Optional)				
Refrigerant type	R32 Environmentally Friendly Refrigerant				
Compressor	Frequency	3D DC Inverter Technology			
Operation temperature	°C	16 ~ 30			
Applicable area	Sq.ft	247.57 - 365.97		495.14 - 753.47	
Loading quantity	40'HC	Set	170	140	108

Window / Room Air Conditioner 60Hz

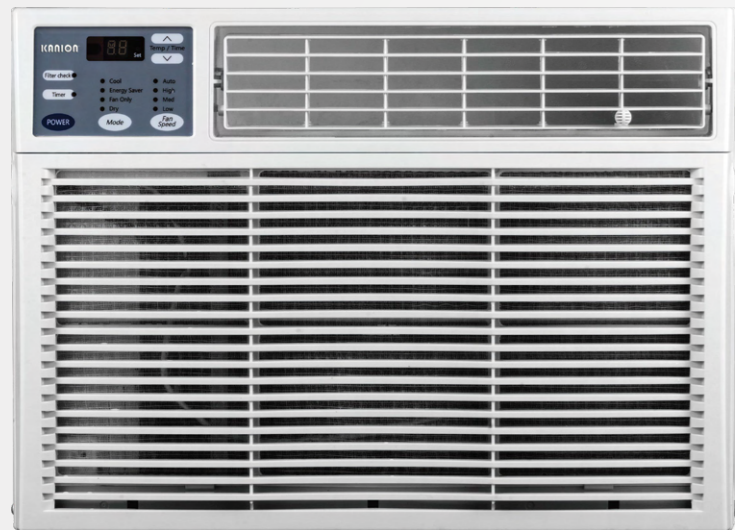

Model number		KW-08R32CSO	KW-10R32CSO	KW-12R32CSO
Power supply		115V / 1Ph / 60Hz		
Capacity	Btu / h	8000	10000	12000
EER	Btu / h / W	12.1	12.0	12.1
Compressor	Frequency	Fixed		
Refrigerant type		R32 Environmentally Friendly Refrigerant		
Control type		Electronic Controller		
Operation temperature	°C	16 ~ 30		
Loading quantity 20'GP / 40'GP / 40'HQ		306 / 630 / 735	195 / 415 / 495	180 / 380 / 452

High ERP 3D DC Inverter Wall Split Air Conditioner / Heat Pump KO1



Model number		KWSM-09R32HFO	KWSM-12R32HFO	KWSM-18R32HFO	KWSM-24R32HFO	
Power supply		220 - 240V / 1Ph / 50Hz				
Heat exchangers		Highly Anti-corrosive Coating on Heat Exchangers / Best efficiency option				
Capacity	Btu / h	9000	12000	18000	24000	
Control type		Remote Controller & Smart App Controller compatible with all major A.I. voice assistants (Standard) / Wire Thermostat Control (Optional)				
Refrigerant type		R32 Environmentally Friendly Refrigerant				
Compressor	Frequency	3D DC Inverter Technology				
Operation temperature	Cooling / Heating	°C				
		-15 ~ 43 / -15 ~ 24				
Applicable area	m ²	10 - 16	15 - 22	21 - 31	23 - 34	
Loading quantity	40'HC	Set	279	275	222	182

3D DC Inverter Multiple Wall Split Air Conditioner / Heat Pump KO2

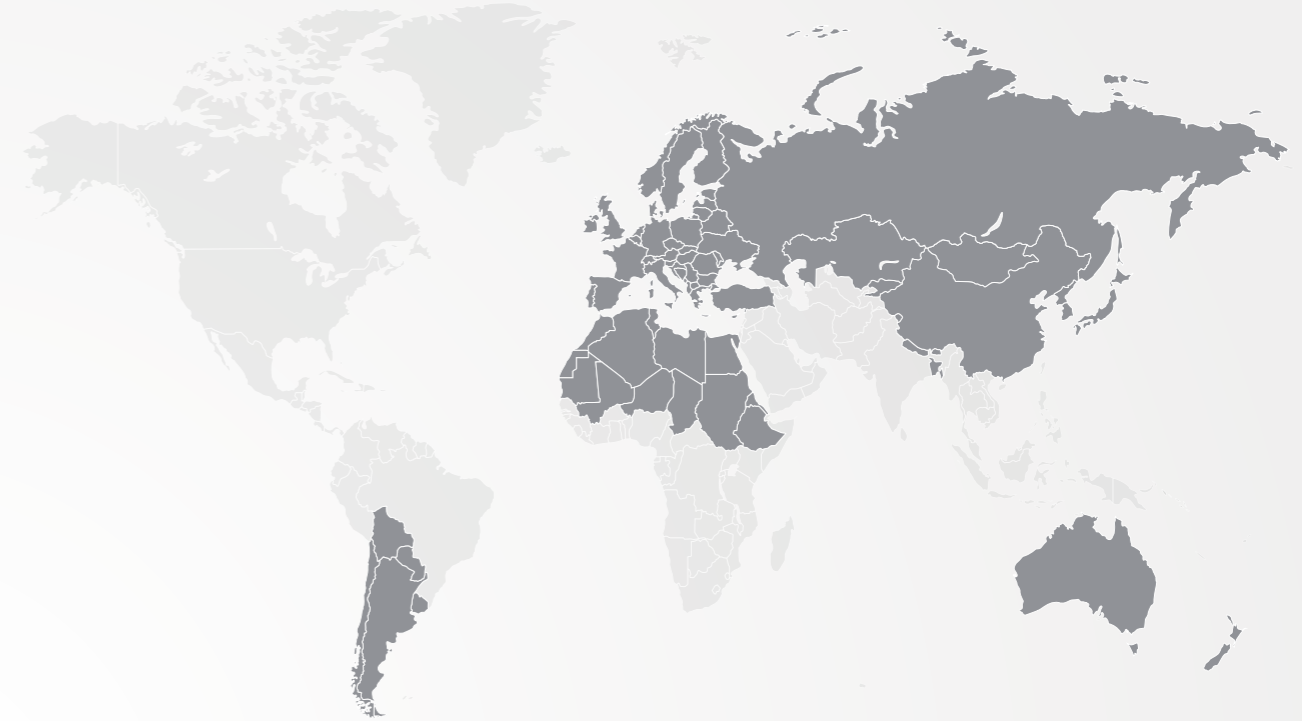
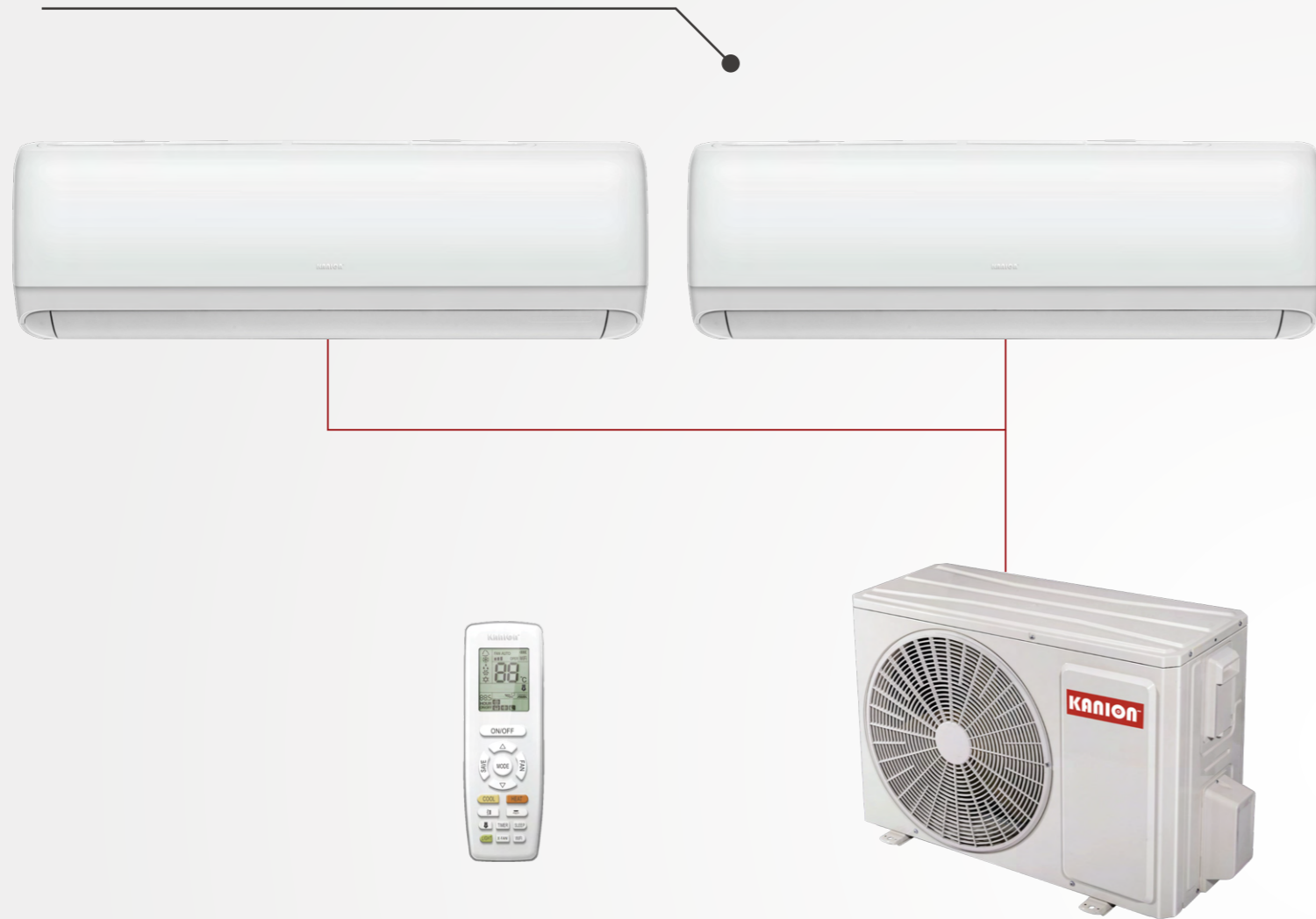

CE RoHS

Model number	KWSMI-09IR32HFOR	KWSMI-12IR32HFOR	KWSMI-18IR32HFOR	KWSMI-24IR32HFOR	
Power supply	208 - 230V / 1Ph / 50Hz				
Heat evaporator	Highly Anti-corrosive Coating on Heat Exchangers / Best efficiency option				
Capacity	Btu / h	9000	12000	18000	24000
Control type	Remote Controller & Smart App Controller compatible with all major A.I. voice assistants & Wire Thermostat Control (standard)				
Refrigerant type	R32 Environmentally Friendly Refrigerant				

Model number	KWSMO-14R32HFOR	KWSMO-18R32HFOR	KWSMO-21R32HFOR	KWSMO-24R32HFOR	KWSMO-28R32HFOR	KWSMO-36R32HFOR	KWSMO-42R32HFOR
Power supply	208 - 230V / 1Ph / 50Hz						
Heat condenser	Highly Anti-corrosive Coating on Heat Exchangers / Best efficiency option						
Refrigerant type	R32 Environmentally Friendly Refrigerant						
Compressor	Frequency	3D DC Inverter Technology					

T3 Saudi Arabia 3D DC Inverter 60Hz Wall Split Air Conditioner KO2

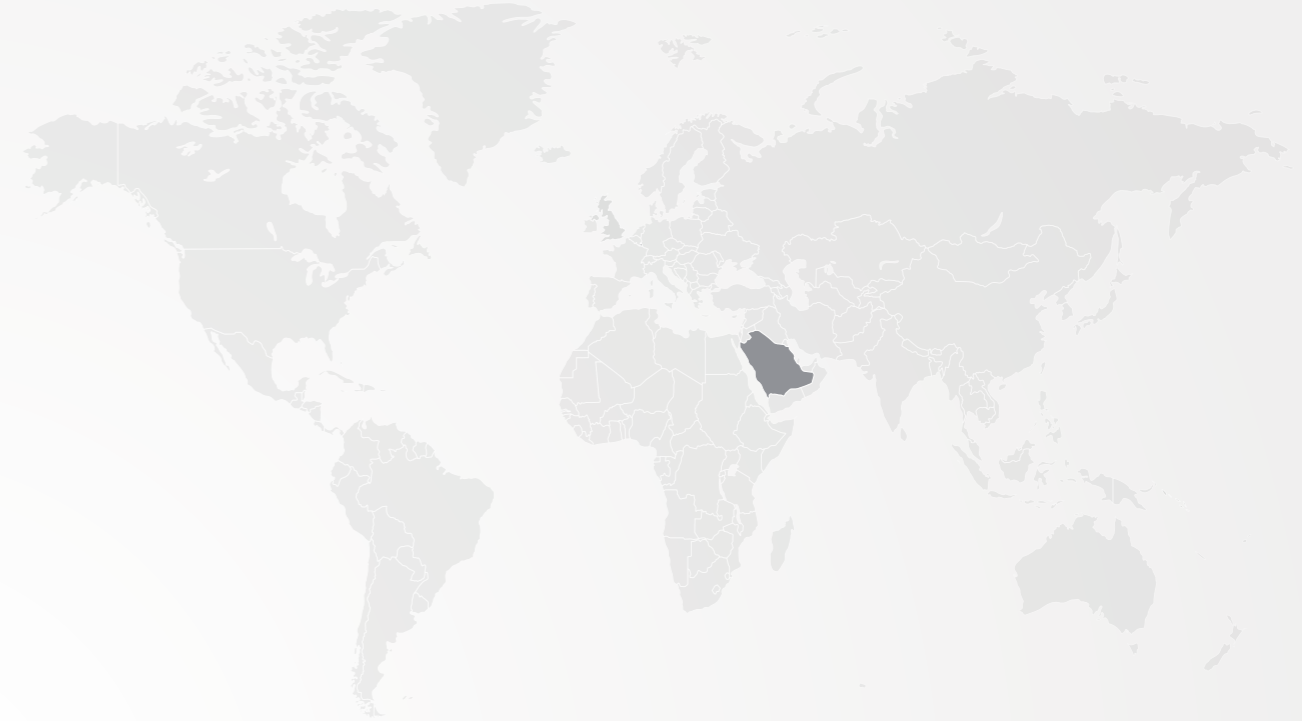
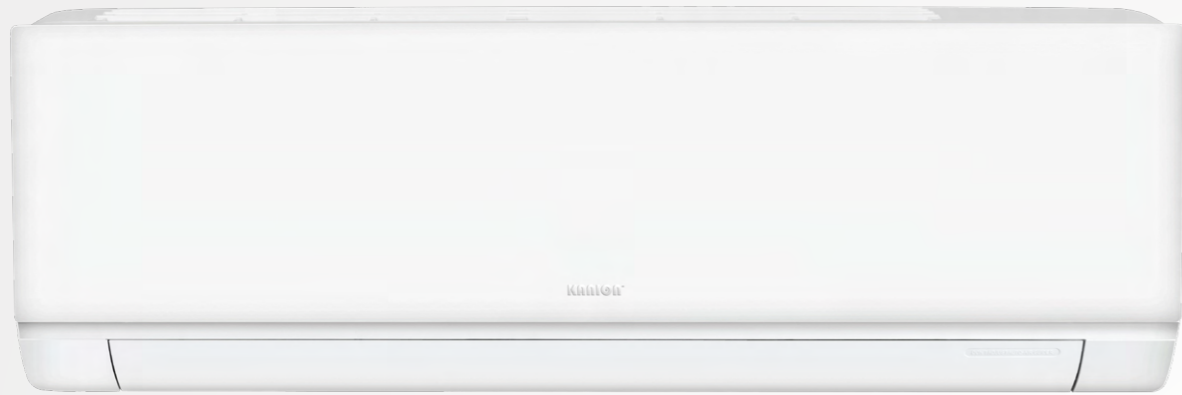

Model number		KWSMT3-12R32CSO	KWSMT3-18R32CSO	KWSMT3-24R32CSO	
Power supply		115V / 1Ph / 60Hz	208 - 230V / 1Ph / 60Hz		
Heat exchangers		Highly Anti-corrosive Coating on Heat Exchangers / Best efficiency option			
Capacity	Btu / h	12000	18000	24000	
Control type		Remote Controller & Smart App Controller compatible with all major A.I. voice assistants (Standard) / Wire Thermostat Control (Optional)			
Refrigerant type		R32 Environmentally Friendly Refrigerant			
Compressor	Frequency	3D DC Inverter Technology			
Operation temperature	°C	16 ~ 30			
Applicable area	m ²	16 - 24	23 - 34	27 - 42	
Loading quantity	40'HC	Set	258	170	132

DELUXE

DELUXE
series



Deluxe Story

Deluxe is a human creation that emerged as an answer to a pressing question on the future of earth. She combines groundbreaking technology with an extraordinary ability to empathize with humans and their natural environment .

With her sleek and elegant human-made design, adorned with gleaming silver and green details, Deluxe constitutes an intelligent and compassionate human companion who's able to go beyond mere temperature regulation. Equipped with advanced sensors that detect air quality and temperature fluctuations, Deluxe can adapt her cooling and heating capabilities to provide optimal comfort and improve the overall well-being of humans, while at the same it significantly minimizes the impact on the surrounding environment.

As the future unfolds, where climate control takes center stage in our lives, inventions like Deluxe become the epitome of air conditioning mastery. They are not just ordinary machines but possess advanced algorithms that enable them to understand and adapt to the unique needs of their human companions as well as to the preservation of our planet. Deluxe and its kind redefine the boundaries of technology, offering a harmonious blend of innovation and empathy to enhance our daily lives.

SEER17.5 - 28.1 3D DC Inverter Wall Split Air Conditioner / Heat Pump KD2

DELUXE
series



Model number	KWSM-06IR410AHS26.5	KWSM-09IR410AHS28.1	KWSM-12IR410AHS25.5	KWSM-18IR410AHS21.5	
Power supply	208 - 230V / 1Ph / 60Hz				
Heat exchangers	Highly Anti-corrosive Coating on Heat Exchangers / Best efficiency option				
Capacity	Btu/hr	6000 (3400 ~ 12000)	9000 (3300 ~ 14300)	12000 (3300 ~ 14300)	18000 (8870 ~ 19400)
SEER	26.5	28.1	25.5	21.5	
Control type	Remote Controller (standard) & Smart App Controller compatible with all major A.I. voice assistants (optional)				
Refrigerant type	R410A Environmentally Friendly Refrigerant				
Compressor	Brand	GMCC			
	Frequency	3D DC Inverter Technology			
Operation temperature	Indoor (Cooling)	16 ~ 32			
	Outdoor (Cooling)	-30 ~ 50			
	Indoor (Heating)	0 ~ 30	0 ~ 27	0 ~ 30	
	Outdoor (Heating)	-30 ~ 24	-30 ~ 30	-30 ~ 24	
Applicable area	Sq.ft	86.11 - 129.17	129.17 - 193.75	172.22 - 247.57	258.33 - 376.74
Loading quantity 20'GP / 40'GP / 40'HQ		96 / 200 / 240	94 / 190 / 220	65 / 137 / 156	

Model number	KWSM-24IR410AHS21.5	KWSM-30IR410AHS20	KWSM-36IR410AHS17.5	
Power supply	208 - 230V / 1Ph / 60Hz			
Heat exchangers	Highly Anti-corrosive Coating on Heat Exchangers / Best efficiency option			
Capacity	Btu/hr	24000 (6850 ~ 27000)	30000 (9070 ~ 30700)	36000 (9300 ~ 38800)
SEER	21.5	20	17.5	
Control type	Remote Controller (standard) & Smart App Controller compatible with all major A.I. voice assistants (optional)			
Refrigerant type	R410A Environmentally Friendly Refrigerant			
Compressor	Brand	GMCC		
	Frequency	3D DC Inverter Technology		
Operation temperature	Indoor (Cooling)	17 ~ 32		
	Outdoor (Cooling)	-30 ~ 50	-25 ~ 50	
	Indoor (Heating)	0 ~ 30		
	Outdoor (Heating)	-30 ~ 24		
Applicable area	Sq.ft	344.44 - 505.90	430.56 - 635.07	516.67 - 753.47
Loading quantity 20'GP / 40'GP / 40'HQ		39 / 82 / 103		

SEER22.0 3D DC Inverter Multiple Wall Split Air Conditioner / Heat Pump KD2 / KD5

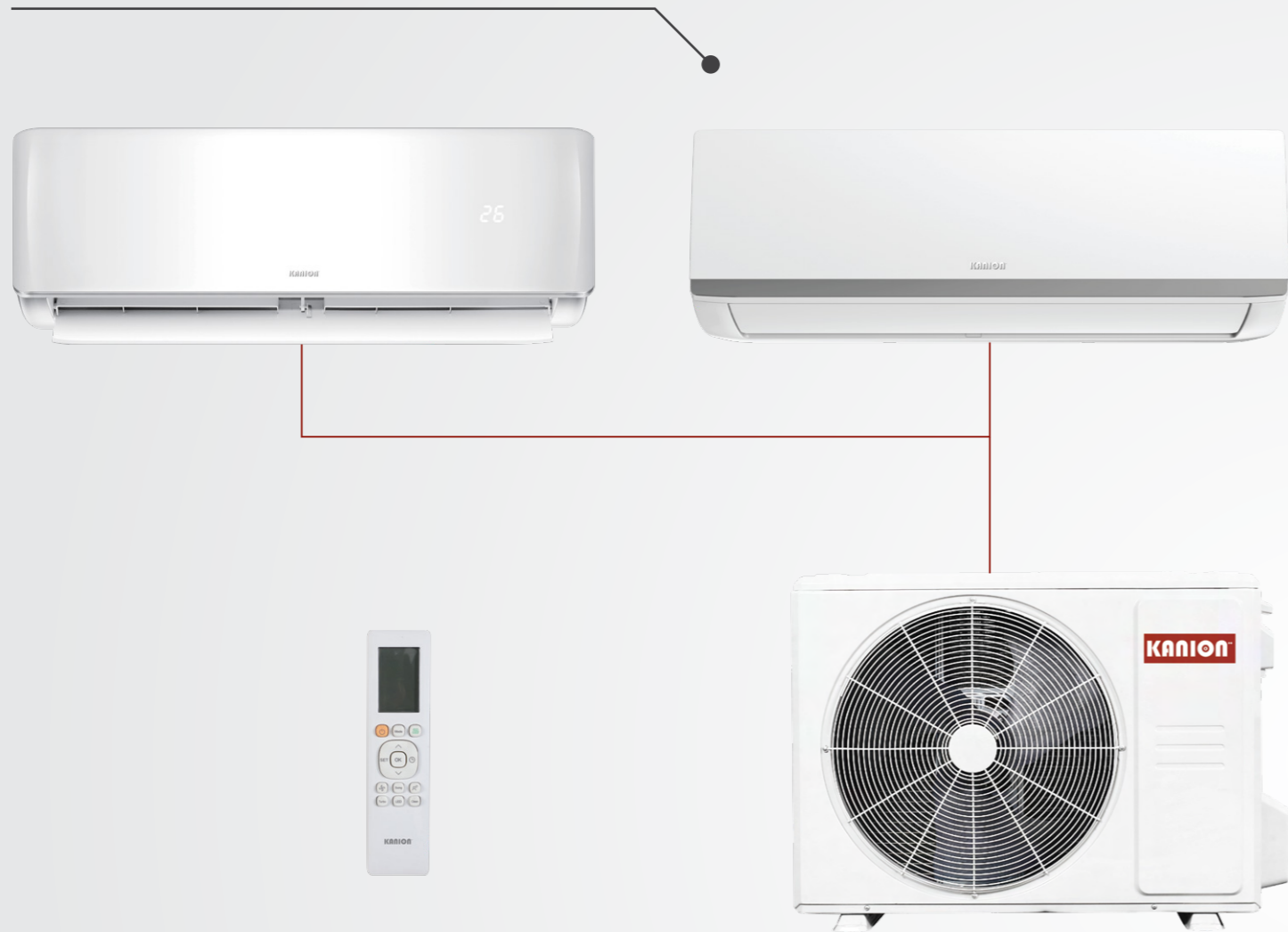

Model number	KWSMI-06R410AIHH	KWSMI-09R410AIHH	KWSMI-12R410AIHH	KWSMI-18R410AIHH	KWSMI-24R410AIHH	KWSMI-30R410AIHH	KWSMI-36R410AIHH
Power supply	208 - 230V / 1Ph / 60Hz						
Heat evaporator	Highly Anti-corrosive Coating on Heat Exchangers / Best efficiency option						
Control type	Remote Controller (standard) & Smart App Controller compatible with all major A.I. voice assistants (optional)						
Loading quantity 20'GP / 40'GP / 40'HQ	370 / 760 / 860	300 / 630 / 720	195 / 400 / 464				130 / 264 / 300



Model number	KWSMO-18R410AIHH	KWSMO-27R410AIHH	KWSMO-36R410AIHH	KWSMO-48R410AIHH	KWSMO-55R410AIHH
Power supply	208 - 230V / 1Ph / 60Hz				
Heat condenser	Highly Anti-corrosive Coating on Heat Exchangers / Best efficiency option				
Refrigerant type	R410A Environmentally Friendly Refrigerant				
Compressor	GMCC				
	3D DC Inverter Technology				
Loading quantity 20'GP / 40'GP / 40'HQ	84 / 171 / 171	44 / 96 / 138			22 / 48 / 48

SEER20.0 - 21.0 3D DC Inverter Wall Split Air Conditioner KD5

DELUXE
series



Model number	KWSM-12IR410ACS21MVL	KWSM-09IR410ACS20.5MV	KWSM-12IR410ACS21MV	KWSM-18IR410ACS21MV	KWSM-24IR410ACS20MV	
Power supply	115V / 1Ph / 60Hz		208 - 230V / 1Ph / 60Hz			
Heat exchangers	Highly Anti-corrosive Coating on Heat Exchangers / Best efficiency option					
Capacity	Btu / hr	11500	9000	11500	17500	22000
SEER	21.0	20.5	21.0		20.0	
Control type	Remote Controller (standard) & Smart App Controller compatible with all major A.I. voice assistants (optional)					
Refrigerant type	R410A Environmentally Friendly Refrigerant					
Compressor	Brand	GMCC				
	Frequency	3D DC Inverter Technology				
Operation temperature	Indoor (Cooling)	16 ~ 32				
	Outdoor (Cooling)	°C	0 ~ 50	-15 ~ 50	0 ~ 50	
Applicable area	Sq.ft	161.46 - 236.81	129.17 - 139.75	161.46 - 236.81	247.57 - 365.97	312.15 - 462.85
Loading quantity	20'GP / 40'GP / 40'HQ	130 / 276 / 302	138 / 282 / 312	130 / 276 / 302	88 / 186 / 220	78 / 168 / 194

Portable / Mobile Air Conditioner / Heat Pump 60Hz

DELUXE
series



Model number	KP-06R32CS	KP-07R32CS	KP-08R32HS	KP-10R32CS	KP-10R32HS
Power supply	115V / 1Ph / 60Hz				
Heat exchangers	Highly Anti-corrosive Coating on Heat Exchangers / Best efficiency option				
Capacity	Btu / hr	10000	12000	13500	
Control type	Multifunctional Remote Controller				
Refrigerant type	R32 Environmentally Friendly Refrigerant				
Compressor	Brand	GMCC			
	Frequency	Fixed			
Loading quantity	20'GP / 40'GP / 40'HQ	132 / 274 / 405		114 / 238 / 353	

Window / Room Air Conditioner 60Hz



Model number	KW-05R32CSL	KW-06R32CSL	KW-10R32CSL	KW-12R32CSL	
Power supply	115V / 1Ph / 60Hz				
Capacity	Btu/h	5000	6000	10000	12000
CEER	Btu/h/W	12.1	11.0	12.0	10.9
Compressor	Brand	GMCC			
	Frequency	Fixed			
Refrigerant type	R32 Environmentally Friendly Refrigerant				
Control type	Remote Controller (standard) & Smart App Controller compatible with all major A.I. voice assistants (optional)				
Operation temperature	Indoor (cooling / heating)	17-32		17 - 35	
	Outdoor (cooling / heating)	18-43			
Loading quantity	20'GP / 40'GP / 40'HQ	468 / 918 / 1050		190 / 410 / 498	

Model number	KW-12R32CS	KW-18R32CS	KW-25R32CS	
Power supply	220 - 230V / 1Ph / 60Hz			
Capacity	Btu/h	11650	18000 / 17700	25000 / 24700
CEER	Btu/h/W	N/A	11.8	10.3
Compressor	Brand	GMCC		
	Frequency	Fixed		
Refrigerant type	R32 Environmentally Friendly Refrigerant			
Control type	Remote Controller (standard) & Smart App Controller compatible with all major A.I. voice assistants (optional)			
Operation temperature	Indoor (cooling / heating)	17-32		
	Outdoor (cooling / heating)	18-43		
Loading quantity	20'GP / 40'GP / 40'HQ	120 / 255 / 306	96 / 216 / 270	84 / 180 / 225

DC Inverter Window / Room Air Conditioner / Heat Pump 60Hz

DELUXE series



Model number		KW-08R32CSL	KW-10R32CSL	KW-12R32CSL	KW-08R32HSL	KW-12R32HSL
Power supply		115V / 1Ph / 60Hz				
Capacity	Btu/h	8000	10000	12000	8000	12000
CEER	US	15.0	N/A	15.0	14.5	13.3
	Canada	10.9				
Compressor	Brand	GMCC				
	Frequency	DC Inverter Technology				
Refrigerant type		R32 Environmentally Friendly Refrigerant				
Control type		Remote Controller (standard) & Smart App Controller compatible with all major A.I. voice assistants (optional)				
Operation temperature	Indoor (cooling / heating)	17-32			17-32 / 0-27	
	Outdoor (cooling / heating)	18-43				
Loading quantity 20' / 40' / 40'HQ		190 / 410 / 492			185 / 395 / 474	

Dehumidifier 60Hz

DELUXE series



Model number		KD-R410A22SL	KD-R410A30SL	KD-R410A35SL	KD-R410A40SL	KD-R410A40SL	
Power supply		115V / 1Ph / 60Hz					
Heat exchangers		Highly Anti-corrosive Coating on Heat Exchangers / Best efficiency option					
Performance	Moisture removal (18.3 / 13.7°C)	Pints / Day	22.00	30.04	35.02	40.24	49.93
Control type		Electronic Controller					
Refrigerant type		R410A Environmentally Friendly Refrigerant					
Compressor	Brand	GMCC					
	Frequency	Fixed					
RH range manual		35 ~ 85					
Operation temperature		5 ~ 32					
Applicable area		Sq.ft					
Loading quantity 20'GP / 40'GP / 40'HQ		172.22 - 333.68	624.31 - 785.77	710.42 - 871.88	796.53 - 957.99		
		432 / 880 / 1100			288 / 582 / 775		

3D DC Inverter Multiple Wall Split Air Conditioner / Heat Pump KD5

DELUXE
series

MINIVERSAL 



CE RoHS

Model number	KWSMI-07IR32HF	KWSMI-09IR32HF	KWSMI-12IR32HF	KWSMI-18IR32HF	KWSMI-24IR32HF
Power supply	220 - 240V / 1Ph / 50Hz				
Heat evaporator	Highly Anti-corrosive Coating on Heat Exchangers / Best efficiency option				
Control type	Remote Controller (standard) & Smart App Controller compatible with all major A.I. voice assistants (optional)				
Loading quantity 20'GP / 40'GP / 40'HQ	307 / 674 / 780		224 / 491 / 569		185 / 405 / 469

Model number	KWSMO-14IR32HF	KWSMO-18IR32HF	KWSMO-21IR32HF	KWSMO-27IR32HF	KWSMO-28IR32HF	KWSMO-36IR32HF	KWSMO-42IR32HF	
Power supply	220 - 240V / 1Ph / 50Hz							
Heat condenser	Highly Anti-corrosive Coating on Heat Exchangers / Best efficiency option							
Refrigerant type	R32 Environmentally Friendly Refrigerant							
Compressor	Brand							
	GMCC							
		Frequency						
		3D DC Inverter technology						

High ERP 3D DC Inverter Wall Split Air Conditioner / Heat Pump KD2

DELUXE
series

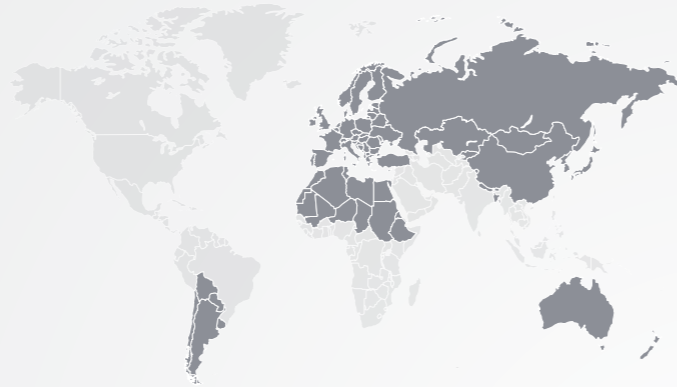

CE RoHS

Model number	KWSM-09IR32HF	KWSM-12IR32HF	KWSM-18IR32HF	KWSM-24IR32HF	
Power supply	220 - 240V / 1Ph / 50Hz				
Heat exchangers	Highly Anti-corrosive Coating on Heat Exchangers / Best efficiency option				
Capacity	Btu / h	9000	12000	18000	24000
Control type	Remote Controller (standard) & Smart App Controller compatible with all major A.I. voice assistants (optional)				
Refrigerant type	R32 Environmentally Friendly Refrigerant				
Compressor	Brand	GMCC			
	Frequency	3D DC Inverter technology			
Operation temperature	Indoor (Cooling)	17 - 32			
	Outdoor (Cooling)	-15 - 50			
	Indoor (Heating)	0 - 30			
	Outdoor (Heating)	-15 - 30			
Applicable area	m ²	12 - 18	16 - 23	24 - 35	32 - 47
Loading quantity	20'GP / 40'GP / 40'HQ	132 / 274 / 305		84 / 180 / 208	66 / 137 / 156

Dehumidifier 50Hz

DELUXE
series



CE RoHS

Model number	KD-R29010F	KD-R29012F	KD-R29016F	KD-R29020F	KD-R29030F	KD-R29050F		
Power supply	220 - 240V / 1Ph / 50Hz							
Heat exchangers	Highly Anti-corrosive Coating on Heat Exchangers / Best efficiency option							
Performance	Moisture removal (30°C / 80%)	L / Day	10.00	12.00	16.00	20.00	30.00	50.00
			Moisture removal (27°C / 60%)	5.50	7.00	9.00	10.00	19.00
Water tank volume	L	2.1	3.0		6.0			
Control type	Electronic Controller							
Refrigerant type	R290 Environmentally Friendly Refrigerant							
Compressor	Brand	Tatung		GMCC				
	Frequency	Fixed						
RH Range manual	%	35 ~ 85						
Operation temperature	°C	5 ~ 32						
Applicable area	m ²	16 - 31	20 - 35	29 - 44	37 - 42	58 - 73	101 - 116	
Loading quantity	20'GP / 40'GP / 40'HQ	720 / 1485 / 1780		480 / 976 / 1220		432 / 880 / 1100	288 / 582 / 775	

Portable / Mobile Air Conditioner / Heat Pump 50Hz

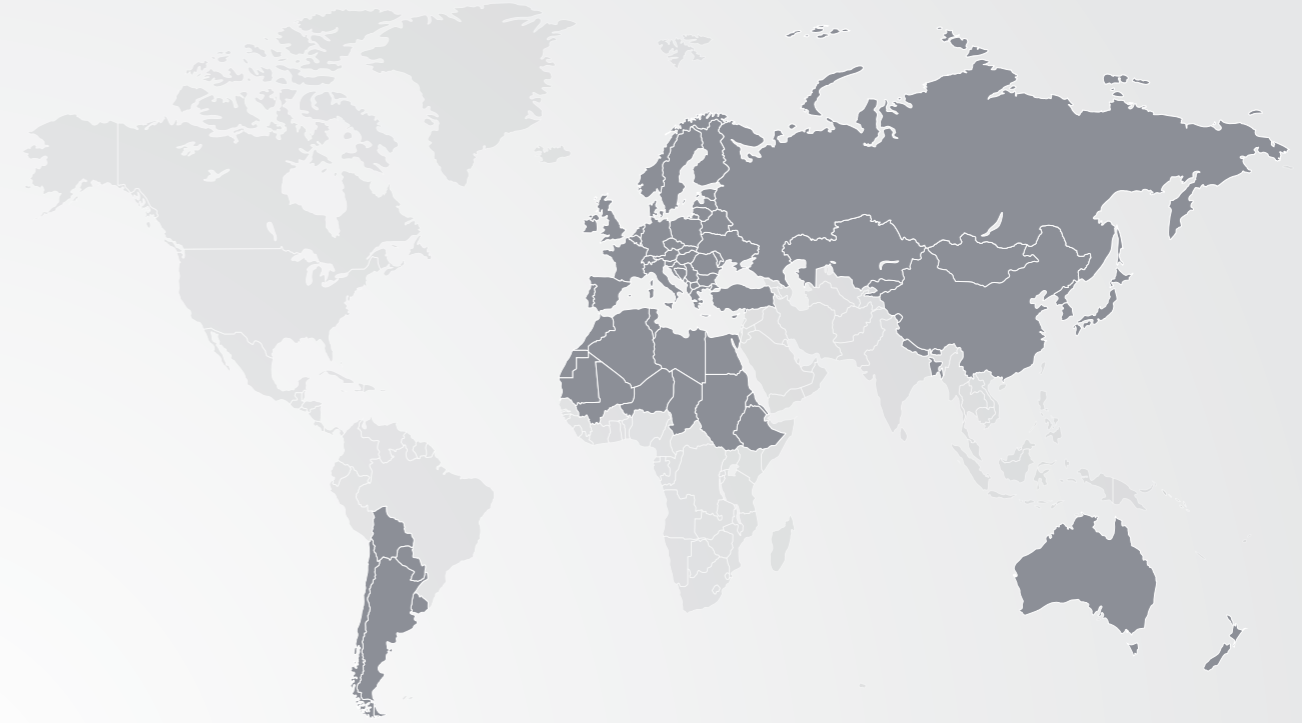
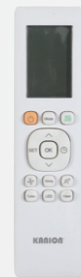

CE RoHS

Model number	KPH-07R290CF	KPH-08R290CF	KPH-09R290CF	KPQ-09R290CF
Power supply	220 - 240V / 1Ph / 50Hz			
Heat exchangers	Highly Anti-corrosive Coating on Heat Exchangers / Best efficiency option			
Capacity	Btu/hr	7000	8000	9000
Control type	Multifunctional Remote Controller			
Refrigerant type	R290 Environmentally Friendly Refrigerant			
Compressor	Brand	GMCC		
	Frequency	Fixed		
Operation temperature	°C	17 ~ 35		
Applicable area	m ²	9 - 14	11 - 16	12 - 18
	Sq.ft	96.88 - 150.69	118.4 - 172.22	129.17 - 198.75
Loading quantity 20'GP / 40'GP / 40'HQ		174 / 356 / 534		96 / 200 / 300

Model number	KPD-10R290CF	KPD-12R290CF	KPD-14R290CF	KPD-12R290HF	
Power supply	220 - 240V / 1Ph / 50Hz				
Heat exchangers	Highly Anti-corrosive Coating on Heat Exchangers / Best efficiency option				
Capacity	Btu/hr	10000	12000	14000	12000
Control type	Multifunctional Remote Controller				
Refrigerant type	R290 Environmentally Friendly Refrigerant				
Compressor	Brand	GMCC			
	Frequency	Fixed			
Operation temperature	Indoor	°C			17 ~ 35
Applicable area	m ²	13 - 20	16 - 23	19 - 27	16 - 23
	Sq.ft	139.93 - 215.28	172.22 - 247.57	204.51 - 290.63	172.22 - 247.57
Loading quantity 20'GP / 40'GP / 40'HQ		114 / 238 / 353			

Window / Room Air Conditioner / Heat Pump 50Hz



CE RoHS

Model number	KW-071R410ACS	KW-071R410ACS	KW-091R410AHS	KW-091R410ACS	KW-091R410ACS	KW-121R410AHS
Power supply	220 - 240V / 1Ph / 50Hz					
Heat exchangers	Highly Anti-corrosive Coating on Heat Exchangers / Best efficiency option					
Capacity	7000		9000		8800	
Control type	Remote	Mechanical	Remote		Mechanical	Remote
Refrigerant type	R410A Environmentally Friendly Refrigerant					
Compressor	GMCC					
	Fixed					
Operation temperature	Indoor (cooling / heating)		17 ~ 32		17 ~ 32 / 0 ~ 27	
	Outdoor (cooling / heating)		18 ~ 43		18 ~ 43 / -5 ~ 24	
Applicable area	96.88 - 150.69		129.17 - 193.75		129.17 - 182.99	
Loading quantity 20' / 40' / 40'HQ	200 / 420 / 501	210 / 420 / 504	135 / 285 / 341	200 / 420 / 501	210 / 420 / 504	84 / 176 / 218

Model number	KW-121R410ACS	KW-121R410ACS	KW-181R410ACS	KW-181R410ACS	KW-241R410ACS
Power supply	220 - 240V / 1Ph / 50Hz				
Heat exchangers	Highly Anti-corrosive Coating on Heat Exchangers / Best efficiency option				
Capacity	12000		18000		23500
Control type	Remote	Mechanical	Remote	Mechanical	
Refrigerant type	R410A Environmentally Friendly Refrigerant				
Compressor	GMCC				
	Fixed				
Operation temperature	Indoor (cooling)		17 ~ 32		
	Outdoor (cooling)		18 ~ 43		
Applicable area	172.22 - 247.57		258.33 - 376.74		333.68 - 495.14
Loading quantity 20' / 40' / 40'HQ	135 / 285 / 341	135 / 285 / 342	84 / 180 / 225		72 / 156 / 195

Floor Standing Air Conditioner / Heat Pump New Environmentally Friendly Refrigerant

DELUXE
series



CE RoHS

Model number	KFS-24R410AHF	KFS-48R410AHF	KFS-50R410AHF	
Power supply	220 - 240V / 1Ph / 50Hz		380 - 415V / 3Ph / 50Hz	
Heat exchangers	Highly Anti-corrosive Coating on Heat Exchangers / Best efficiency option			
Capacity	Btu/h	24000	48000	58500
Control type	Remote Controller			
Refrigerant type	R410A Environmentally Friendly Refrigerant			
Compressor	Brand	GMCC	Panasonic	
	Frequency	3D DC Inverter Technology		
Operation temperature	°C	17 ~ 32 / 0 ~ 30		
Applicable area	m ²	32 - 47	64 - 94	78 - 114
Loading quantity	20'GP / 40'GP / 40'HQ	32 / 71 / 77	18 / 38 / 48	17 / 34 / 42

T3 Saudi Arabia Standard 3D DC Inverter Wall Split Air Conditioner / Heat Pump KD5

DELUXE
series



Model number	KWSMT3-12IR410AHF	KWSMT3-18IR410AHF	KWSMT3-22IR410AHF	KWSMT3-27IR410AHF	
Power supply	220 - 240V / 1Ph / 50Hz				
Heat exchangers	Highly Anti-corrosive Coating on Heat Exchangers / Best efficiency option				
Capacity	Cooling (T1)	Cooling (T3)	Btu/h		
	11800	17000	22000	27000	
	10500	15800	19300	23228	
Control type	Remote Controller (standard) & Smart App Controller compatible with all major A.I. voice assistants (optional)				
Refrigerant type	R410A Environmentally Friendly Refrigerant				
Compressor	Brand	GMCC			
	Frequency	3D DC Inverter Technology			
Operation temperature	°C	17 ~ 32			
Applicable area	m ²	16 ~ 23	23 ~ 33	29 ~ 43	36 ~ 53
Loading quantity	20'GP / 40'GP / 40'HQ	84 / 178 / 214	60 / 126 / 142	44 / 92 / 108	36 / 76 / 88

T3 Saudi Arabia Standard Fixed Frequency Wall Split Air Conditioner / Heat Pump KD5

DELUXE series

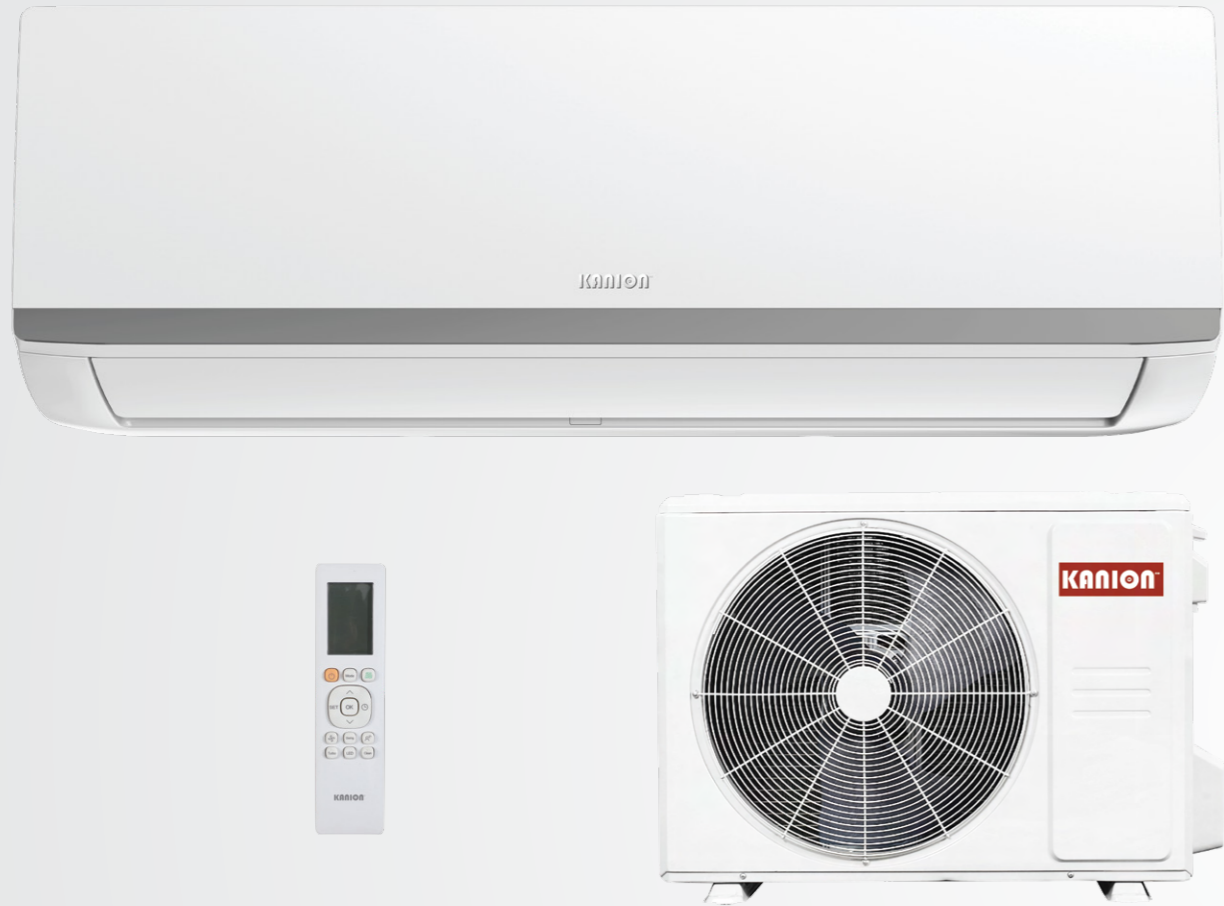

Model number	KWSMT3-12R410AHS	KWSMT3-12R410ACS	KWSMT3-18R410AHS	KWSMT3-18R410ACS	KWSMT3-22R410AHS	KWSMT3-22R410ACS
Power supply	230V / 1Ph / 60Hz					
Heat exchangers	Highly Anti-corrosive Coating on Heat Exchangers / Best efficiency option					
Capacity	Cooling (T1)	11800	12000	18000		22000
	Cooling (T3)	10300	10500	15900	15500	18400 / 18200
Control type	Remote Controller (standard) & Smart App Controller compatible with all major A.I. voice assistants (optional)					
Refrigerant type	R410A Environmentally Friendly Refrigerant					
Compressor	Brand	GMCC				
	Frequency	Fixed				
Operation temperature						17~30
Application area (Cooling Standard)	16 ~ 23		24 ~ 35		29 ~ 43	
Loading quantity 20'GP / 40'GP / 40'HQ	86 / 174 / 204		64 / 130 / 149		57 / 127 / 147 / 44 / 92 / 108	

Model number	KWSMT3-28R410AHS	KWSMT3-28R410ACS	KWSMT3-32R410AHS	KWSMT3-32R410ACS
Power supply	230V / 1Ph / 60Hz			
Heat exchangers	Highly Anti-corrosive Coating on Heat Exchangers / Best efficiency option			
Capacity	Cooling (T1)	27000	28000	31400
	Cooling (T3)	23800	24000	26800
Control type	Remote Controller (standard) & Smart App Controller compatible with all major A.I. voice assistants			
Refrigerant type	R410A Environmentally Friendly Refrigerant			
Compressor	Brand	GMCC		Highly
	Frequency	Fixed		
Operation temperature				17~30
Application area (Cooling Standard)	36 ~ 52		42 ~ 61	
Loading quantity 20'GP / 40'GP / 40'HQ	64 / 130 / 149	36 / 76 / 88		36 / 73 / 90

T3 Middle East Fixed Frequency Wall Split Air Conditioner KD5

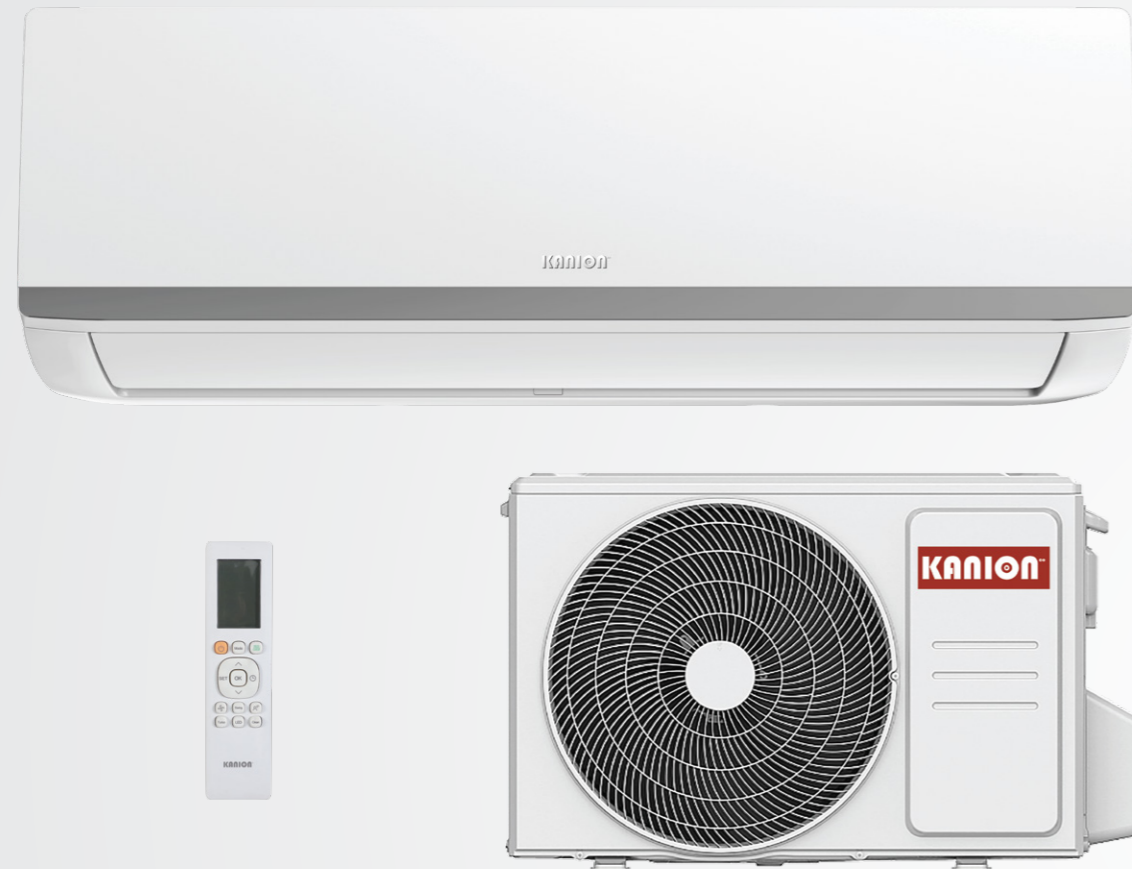

Model number	KWSMT3-12R410ACF	KWSMT3-18R410ACF	KWSMT3-23R410ACF	KWSMT3-28R410ACF	KWSMT3-32R410ACF	
Power supply	220 - 240V / 1Ph / 50Hz				220 - 240V / 1Ph / N/A	
Heat exchangers	Highly Anti-corrosive Coating on Heat Exchangers / Best efficiency option					
Capacity	Cooling (T1)	12000	18000	23300	28300	32000
	Cooling (T3)	10600	15500	20000	25100	27800
Control type	Remote Controller (standard) & Smart App Controller compatible with all major A.I. voice assistants (optional)					
Refrigerant type	R410A Environmentally Friendly Refrigerant					
Compressor	Brand	GMCC			HL	
	Frequency	Fixed				
Operation temperature	°C					
Applicable area	16 ~ 23	24 ~ 35	31 ~ 46	38 ~ 55	43 ~ 63	
Loading quantity	20'GP / 40'GP / 40'HQ	90 / 190 / 222	78 / 168 / 194	64 / 134 / 156	36 / 76 / 88	



REX



Rex Series

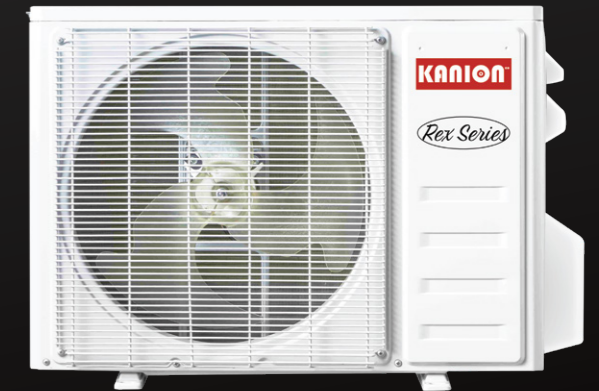

Rex Story

Rex is a man who consciously decided to be enhanced with technology in order to be able to upgrade humanity's daily life experiences. Thus his superpower is his innumerable tools that improve smart compatibility and air health beyond classic practices.

Rex constitutes the ultimate answer to smart connectivity and the completion of the smart home concept, hence called the king of smart features. It's harmonious compatibility with a state-of-the-art smart app controller offers so many interesting tools far beyond temperature settings. With Rex, every feature on a classic remote controller is basically available on the smart app controller of any smart phone, enhanced also by many interesting new additions.

When it comes to fellow humans' indoor air quality, Rex is as committed. With features such as Built-in Bipolar Ionic Generator (BIG) and UVC Sterilization, Rex generates large volumes of plasma, atoms, and strong oxidization substance, which could damage & kill airborne bacteria and viruses.

SEER20.0 - SEER23.0 DC Inverter Wall Split Air Conditioner / Heat Pump KR3

Rex Series

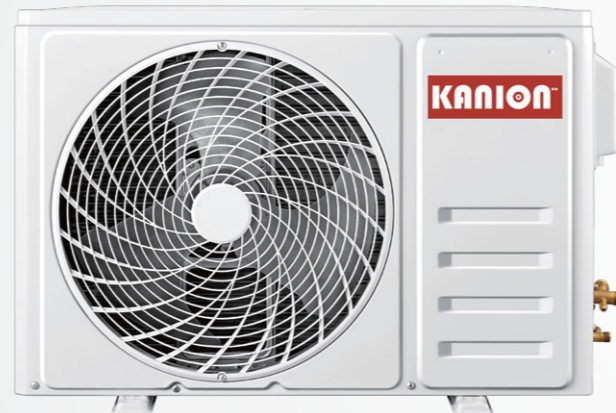
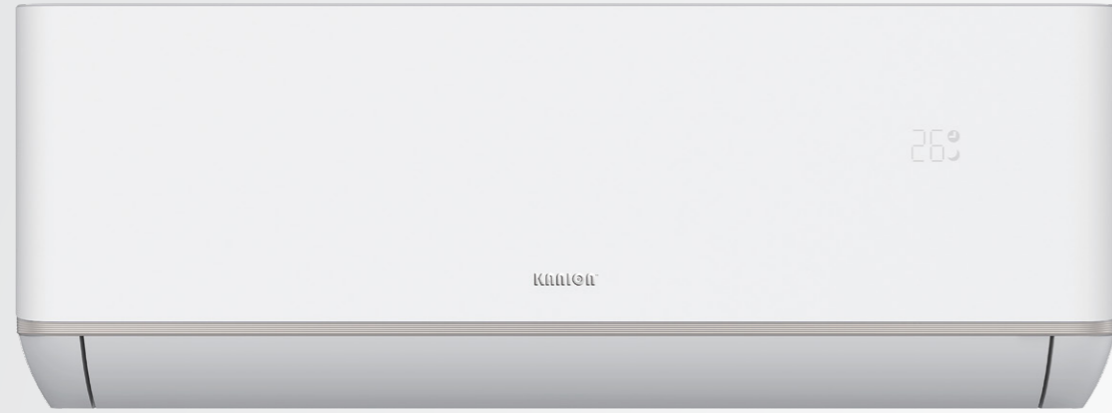

Model number	KWSM-09IR410AHS22L	KWSM-12IR410AHS22L	KWSM-09IR410AHS23	
Power supply	115V / 1Ph / 60Hz		208 - 230V / 1Ph / 60Hz	
Heat exchangers	Highly Anti-corrosive Coating on Heat Exchangers / Best efficiency option			
Capacity	Btu / h	9000	12000	9000
SEER	22.0		23.0	
SEER2	23.0	22.0	23.5	
Control type	Remote Controller (standard) & Smart App Controller compatible with all major A.I. voice			
Refrigerant type	R410A Environmentally Friendly Refrigerant			
Compressor	Brand	GMCC		
	Frequency	DC Inverter Technology		
Operation temperature	Indoor (cooling / heating)	>=17 / <=30		
	Outdoor (cooling /heating)	-15 ~ 55 / -25 ~ 30		
Applicable area	Sq.ft	Up to 400	Up to 550	Up to 400
Loading quantity 40'HQ		229	224	229

Model number	KWSM-12IR410AHS23	KWSM-18IR410AHS21.5	KWSM-24IR410AHS20	
Power supply	208 - 230V / 1Ph / 60Hz			
Heat exchangers	Highly Anti-corrosive Coating on Heat Exchangers / Best efficiency option			
Capacity	Btu / h	12000	18000	23000
SEER	23.0	21.5	20.0	
SEER2	23.0	22.0	20.0	
Control type	Remote Controller (standard) & Smart App Controller compatible with all major A.I. voice			
Refrigerant type	R410A Environmentally Friendly Refrigerant			
Compressor	Brand	GMCC	Sanyo	
	Frequency	DC Inverter Technology		
Operation temperature	Indoor (cooling / heating)	>=17 / <=30		
	Outdoor (cooling /heating)	-15 ~ 55 / -25 ~ 30		
Applicable area	Sq.ft	Up to 550	Up to 1000	Up to 1500
Loading quantity 40'HQ		224	150	117

SEER 16.0 DC Inverter Wall Split Air Conditioner KR3

Rex Series



Model number	KWSM-12IR410ACS16L	KWSM-12IR410ACS16	KWSM-18IR410ACS16	KWSM-24IR410ACS16	
Power supply	115V / 1Ph / 60Hz		208 - 230V / 1Ph / 60Hz		
Heat exchangers	Highly Anti-corrosive Coating on Heat Exchangers / Best efficiency option				
Capacity	Btu/h	12000 (2050 ~ 12625)	12000 (2730 ~ 12965)	18000 (4095 ~ 19500)	24000 (5120 ~ 24900)
Control type	Remote Controller (standard) & Smart App Controller compatible with all major A.I. voice assistants (optional)				
Refrigerant type	R410A Environmentally Friendly Refrigerant				
Compressor	Brand	GMCC			
	Frequency	DC Inverter Technology			
Applicable area	m ²	15 ~ 23	20 ~ 35	30 ~ 50	
Loading quantity 40'HQ	300		230	165	

High ERP DC Inverter Wall Split Air Conditioner / Heat Pump KR1

Rex Series



Model number	KWSM-09IR32HF	KWSM-12IR32HF	KWSM-18IR32HF	KWSM-24IR32HF	
Power supply	220 - 240V / 1Ph / 50Hz				
Heat exchangers	Highly Anti-corrosive Coating on Heat Exchangers / Best efficiency option				
Capacity	W	2610 (940~3700)	3510 (1000~4600)	5100 (1250~5920)	6910 (1830~7820)
Control type	Remote Controller (standard) & Smart App Controller compatible with all major A.I. voice assistants (optional)				
Refrigerant type	R32 Environmentally Friendly Refrigerant				
Compressor	Brand	GMCC		Sanyo	
	Frequency	DC Inverter Technology			
Operation temperature	°C	16 - 31			
Applicable area	m ²	9 ~ 16	14 ~ 22	20 ~ 35	27 ~ 45
Loading quantity 40'HQ	268		250	155	120

PREMIUM



Premium Story

Engineer Premium's life target has always been to make technology available to everyone. Determined to achieve that, a young Premium immersed himself in the realms of science and technology.

Day and night, he tirelessly worked, when, fueled by his growing knowledge and passion, Premium managed to combine all the latest technological advances in the refrigeration industry into an air conditioner that could be owned by anyone, regardless the budget available. Because, despite the impressive combination of features, Premium's air conditioners were designed to be affordable.

As time passed, Engineer Premium's expertise in climate control flourished. He continuously improved his air conditioners, ensuring that every house on earth was perfectly cooled and heated.

SEER17.0 - SEER20.0 / DIY DC Inverter Wall Split Air Conditioner / Heat Pump KP6



Model number	KWSM-09IR410AHS20LP	KWSM-12IR410AHS20LP	KWSM-09IR410AHS19P	KWSM-12IR410AHS19P
Power supply	115V / 1Ph / 60Hz		208 - 230V / 1Ph / 60Hz	
Heat exchangers	Highly Anti-corrosive Coating on Heat Exchangers / Best efficiency option			
Capacity	Rated	Btu / h	9000	12000
SEER	20		19	
Control type	Remote Controller (standard) & Smart App Controller compatible with all major A.I. voice assistants (optional)			
Refrigerant type	R410A Environmentally Friendly Refrigerant			
Compressor	Brand	GMCC		
	Frequency	DC Inverter Technology		
Operation temperature	°C			
	16~31			
Applicable area	Sq.ft			
	129.17 - 182.99	182.99 - 269.10	129.17 - 182.99	182.99 - 269.10
Loading quantity	20'GP/ 40'GP/ 40'HQ		239 / 190 / 94	
			268 / 161 / 105	

Model number	KWSM-18IR410AHS19P	KWSM-24IR410AHS18P	KWSM-36IR410AHS17P		
Power supply	230V / 1Ph / 60Hz				
Heat exchangers	Highly Anti-corrosive Coating on Heat Exchangers / Best efficiency option				
Capacity	Rated Cooling (95 °F / 35 °C)	Btu / h	18000	24000	36000
SEER	19	18	17		
Control type	Remote Controller (standard) & Smart App Controller compatible with all major A.I. voice				
Refrigerant type	R410A Environmentally Friendly Refrigerant				
Compressor	Brand	Sanyo		GMCC	
	Frequency	DC Inverter Technology			
Operation temperature	°C				
	16~31				
Applicable area	Sq.ft				
	258.33 - 430.56	322.92 - 512.67			
Loading quantity	20'GP/ 40'GP/ 40'HQ		200 / 161 / 79	59 / 121 / 150	109 / 88 / 43

SEER21.5 - SEER22.0 DC Inverter Multiple Wall Split Air Conditioner / Heat Pump KP1

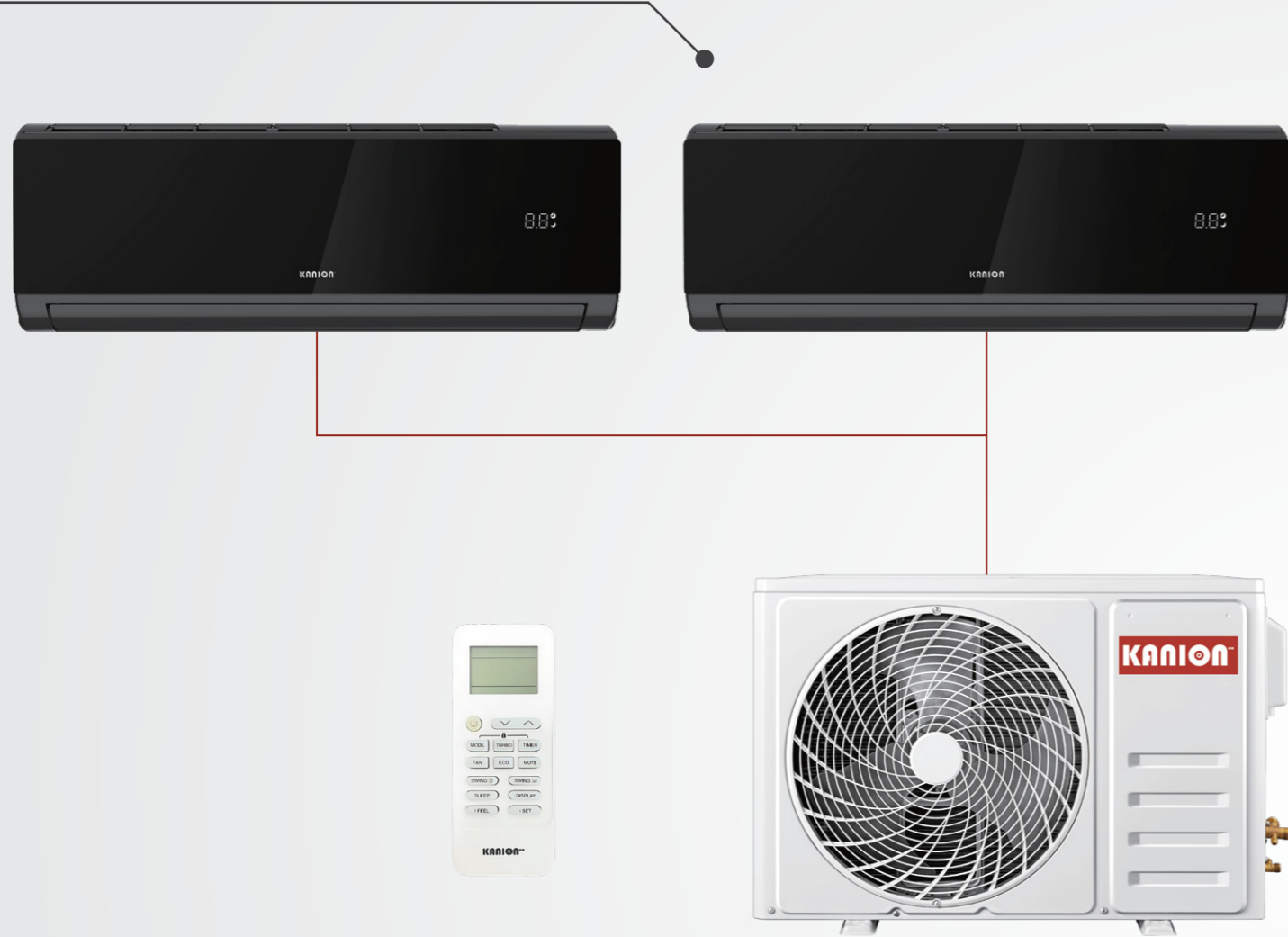

Model number	KWSMI-09IR410AHSP	KWSMI-12IR410AHSP	KWSMI-18IR410AHSP
Power supply	208 - 230V / 1Ph / 60Hz		
Heat evaporator	Highly Anti-corrosive Coating on Heat Exchangers / Best efficiency option		
Capacity	Rated Cooling (95 °F / 35 °C)	Btu/h	
	9000	12000	18000
Control type	Remote Controller (standard) & Smart App Controller compatible with all major A.I. voice		
Loading quantity 20'GP / 40'GP / 40'HC	302 / 638 / 718		198 / 417 / 490

Model number	KWSMO-18IR410AHSP	KWSMO-27IR410AHSP	KWSMO-36IR410AHSP
Power supply	208 - 230V / 1Ph / 60Hz		
Heat condenser	Highly Anti-corrosive Coating on Heat Exchangers / Best efficiency option		
Refrigerant type	R410A Environmentally Friendly Refrigerant		
Compressor	Brand	Sanyo	GMCC
	Frequency	DC Inverter technology	
Loading quantity 20'GP / 40'GP / 40'HC	89 / 188 / 189	44 / 96 / 143	54 / 114 / 114

SEER 17.0 - 20.0 DC Inverter Wall Split Air Conditioner KP1

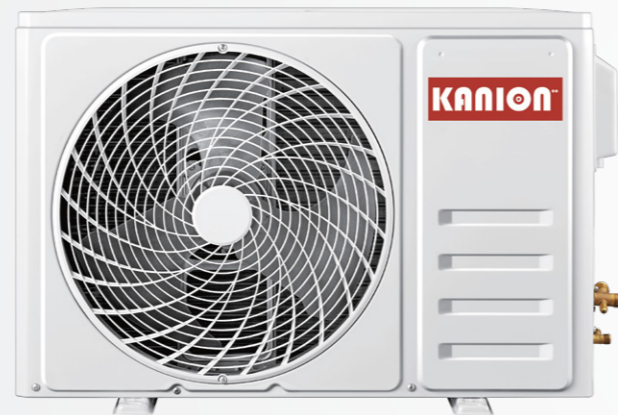

Model number	KWSM-09IR410AHS20LP	KWSM-12IR410AHS20LP	KWSM-09IR410AHS19P	KWSM-12IR410AHS19P	
Power supply	115V / 1Ph / 60Hz		208 - 230V / 1Ph / 60Hz		
Heat exchangers	Highly Anti-corrosive Coating on Heat Exchangers / Best efficiency option				
Capacity	Btu/h	9000	12000	9000	12000
SEER		20.0		19.0	
Control type	Remote Controller (standard) & Smart App Controller compatible with all major A.I. voice assistants				
Refrigerant type	R410A Environmentally Friendly Refrigerant				
Compressor	Brand	GMCC			
	Frequency	DC Inverter Technology			
Applicable area	m²	12 ~ 17	17 ~ 25	12 ~ 17	17 ~ 25
Loading quantity 40'HQ		240		258	

Model number	KWSM-18IR410AHS19P	KWSM-24IR410AHS18P	KWSM-36IR410AHS17P	
Power supply	230V / 1Ph / 60Hz			
Heat exchangers	Highly Anti-corrosive Coating on Heat Exchangers / Best efficiency option			
Capacity	Btu/h	18000	24000	36000
SEER		19.0	18.0	17.0
Control type	Remote Controller (standard) & Smart App Controller compatible with all major A.I. voice assistants			
Refrigerant type	R410A Environmentally Friendly Refrigerant			
Compressor	Brand	Sanyo		
	Frequency	DC Inverter Technology		
Applicable area	m²	24 ~ 40	30 ~ 48	
Loading quantity 40'HQ		184	135	100

Fixed Frequency Wall Split Air Conditioner KP2

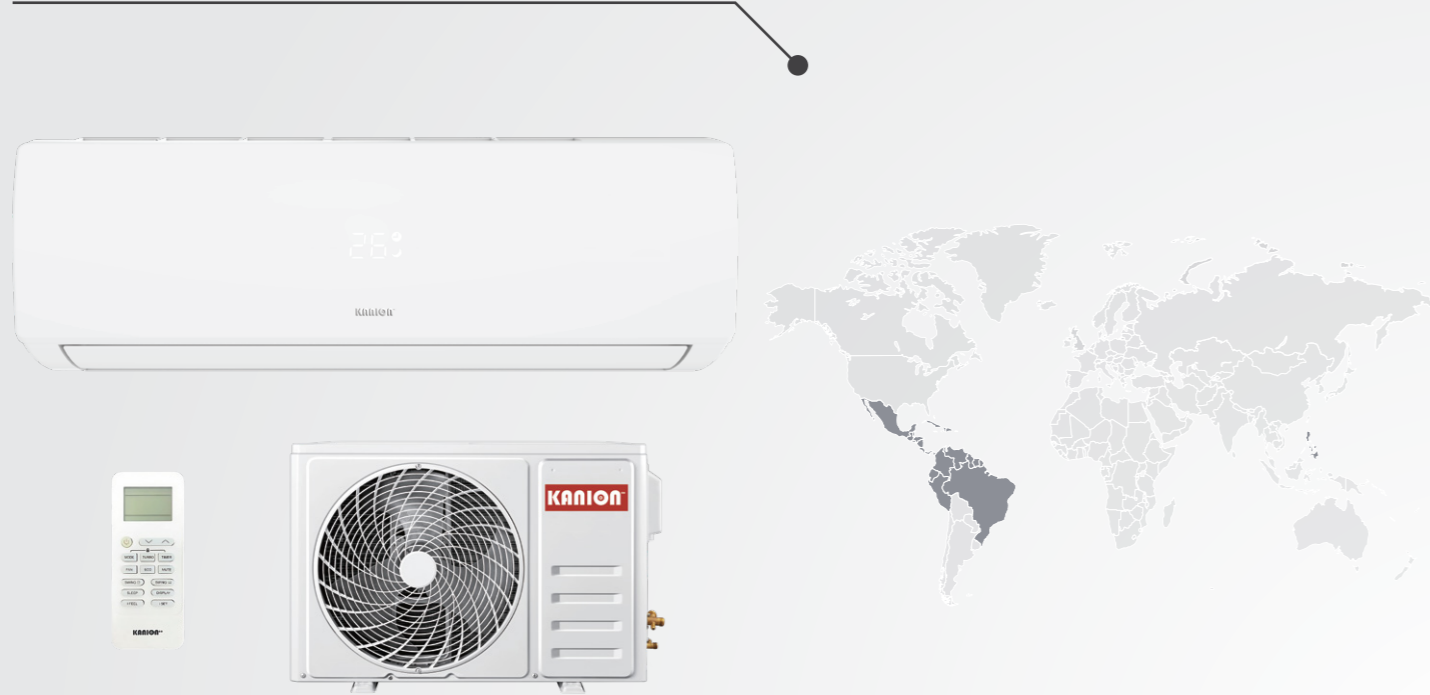

SEER18.0 - 20.0 DC Inverter Wall Split Air Conditioner KP6



Model number	KWSM-12R410ACSL	KWSM-12R410ACS	KWSM-18R410ACS	KWSM-24R410ACS	KWSM-30R410ACS
Power supply	115 / 1Ph / 60Hz		208 - 230V / 1Ph / 60Hz		
Heat exchangers	Highly Anti-corrosive Coating on Heat Exchangers / Best efficiency option				
Capacity	12000		18000	24000	30000
Control type	Remote Controller (standard) & Smart App Controller compatible with all major A.I. voice assistants (optional)				
Refrigerant type	R410A Environmentally Friendly Refrigerant				
Compressor	Brand	Rechi	GMCC	Highly	GMCC
	Frequency	Fixed			
Applicable area	15 ~ 23		20 ~ 35	30 ~ 50	50 ~ 65
Loading quantity 40'HQ	310	350	245	196 / 187 (High Panel)	134

Model number	KWSM-12IR410ACS18	KWSM-18IR410ACS18	KWSM-24IR410ACS18
Power supply	208 - 230V / 1Ph / 60Hz		
Heat exchangers	Highly Anti-corrosive Coating on Heat Exchangers / Best efficiency option		
Capacity	12000 (2047 ~ 12624)		
SEER	18.0	18.0 / 20.0	
Control type	Remote Controller (standard) & Smart App Controller compatible with all major A.I. voice assistants (optional)		
Refrigerant type	R410A environmentally friendly refrigerant		
Compressor	Brand	GMCC	
	Frequency	DC Inverter Technology	
Applicable area	15 ~ 23	25 ~ 40	30 ~ 50
Loading quantity 40'HQ	300	214	180

DC Inverter Wall Split Air Conditioner / Heat Pump KP6



CE RoHS

Model number		KWSM-09IR32HF	KWSM-12IR32HF	KWSM-18IR32HF	KWSM-24IR32HF
Power supply		220 - 240V / 1Ph / 50Hz			
Heat exchangers		Highly Anti-corrosive Coating on Heat Exchangers / Best efficiency option			
Capacity	W	2600 (940~3300)	3400 (1000~3770)	5100 (1250-5910)	6810 (1830~7800)
Control type		Remote Controller (standard) & Smart App Controller compatible with all major A.I. voice assistants			
Refrigerant type		R32 Environmentally Friendly Refrigerant			
Compressor	Brand	Rechi	GMCC	Sanyo	
	Frequency	DC Inverter Technology			
Operation temperature	Indoor (Cooling)	17 - 32			
	Outdoor (Cooling)	-15 - 53			
	Indoor (Heating)	0 - 30			
	Outdoor (Heating)	-20 - 30			
Applicable area	m ²	9 ~ 16	14 ~ 22	20 ~ 35	27 ~ 45
Loading quantity 40'HQ		370	360	208	162

High ERP DC Inverter Wall Split Air Conditioner / Heat Pump KP1



CE RoHS

Model number		KWSM-09IR32HF	KWSM-12IR32HF	KWSM-18IR32HF	KWSM-24IR32HF
Power supply		220 - 240V / 1Ph / 50Hz			
Heat exchangers		Highly Anti-corrosive Coating on Heat Exchangers / Best efficiency option			
Capacity	W	2600 (940 ~ 3300)	3500 (1000 ~ 3770)	5100 (1250 ~ 5910)	6810 (1830 ~ 7800)
Control type		Remote Controller (standard) & Smart App Controller compatible with all major A.I. voice assistants			
Refrigerant type		R32 Environmentally Friendly Refrigerant			
Compressor	Brand	Rechi	GMCC	Sanyo	
	Frequency	DC Inverter Technology			
Operation temperature	Indoor (Cooling)	17 - 32			
	Outdoor (Cooling)	-15 - 53			
	Indoor (Heating)	0 - 30			
	Outdoor (Heating)	-20 - 30			
Applicable area	m ²	9 ~ 16	14 ~ 22	20 ~ 35	27 ~ 45
Loading quantity 40'HQ		330	315	200	145

High ERP DC Inverter Multiple Wall Split Air Conditioner / Heat Pump KP6



Model number	KWSMI-09IR32HF	KWSMI-12IR32HF	KWSMI-18IR32HF	
Power supply	220 - 240V / 1Ph / 50Hz			
Heat evaporator	Highly Anti-corrosive Coating on Heat Exchangers / Best efficiency option			
Capacity	Btu / h	9000	12000	17500
Control type	Remote Controller (standard) & Smart App Controller compatible with all major A.I. voice			

Model number	KWSMO-18IR32HF	KWSMO-27IR32HF	KWSMO-32IR32HF	KWSMO-42IR32HF
Power supply	220 - 240V / 1Ph / 50Hz			
Heat condenser	Highly Anti-corrosive Coating on Heat Exchangers / Best efficiency option			
Compressor	Brand	Rechi	Sanyo	GMCC
Compressor	Frequency	DC Inverter Technology		

Fixed Frequency

Wall Split Air Conditioner / Heat Pump KP1

premium
series

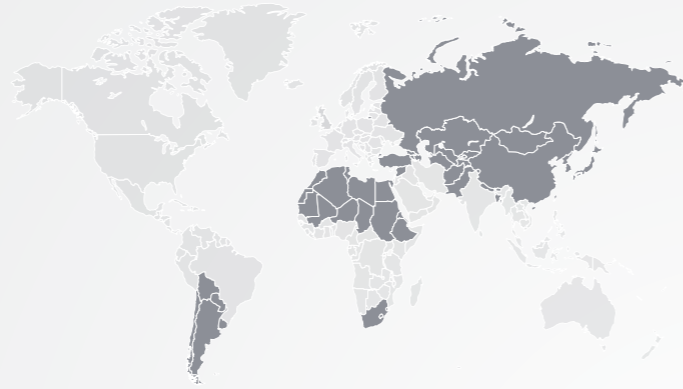

CE RoHS

Model number	KWSM-09R410AHF	KWSM-12R410AHF	KWSM-18R410AHF	KWSM-24R410AHF	
Power supply	220 - 240V / 1Ph / 50Hz				
Heat exchangers	Highly Anti-corrosive Coating on Heat Exchangers / Best efficiency option				
Capacity	Btu/h	9000	12000	18000	24000
Control type	Remote Controller (standard) & Smart App Controller compatible with all major A.I. voice assistants				
Refrigerant type	R410A Environmentally Friendly Refrigerant				
Compressor	Brand	GMCC	Rechi	Hitachi	
	Frequency	Fixed			
Applicable area	m ²	10 ~ 15	20 ~ 25	25 ~ 35	30 ~ 40
Loading quantity 40'HQ		360	310	230	190

DC Inverter

Wall Split Air Conditioner / Heat Pump KP6

premium
series

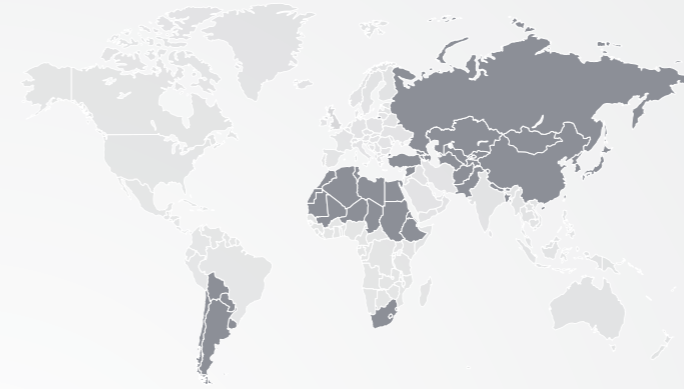

CE RoHS

Model number	KWSM-09IR410AHF	KWSM-12IR410AHF	KWSM-18IR410AHF	KWSM-24IR410AHF	
Power supply	220 - 240V / 1Ph / 50Hz				
Heat exchangers	Highly Anti-corrosive Coating on Heat Exchangers / Best efficiency option				
Capacity	Btu/h	9000 (3210 ~ 11430)	12000 (3480 ~ 13170)	18000 (5500 ~ 20000)	24000 (6825 ~ 27300)
Control type	Remote Controller (standard) & Smart App Controller compatible with all major A.I. voice assistants				
Refrigerant type	R410A Environmentally Friendly Refrigerant				
Compressor	Brand	GMCC	Sanyo		
	Frequency	DC Inverter Technology			
Operation temperature	°C	-15 ~ 53		-15 ~ 60	
Applicable area	m ²	9 ~ 16	14 ~ 22	25 - 40	30 ~ 50
Loading quantity 40'HQ		320	310	200	150

Fixed Frequency Wall Split Air Conditioner KP1

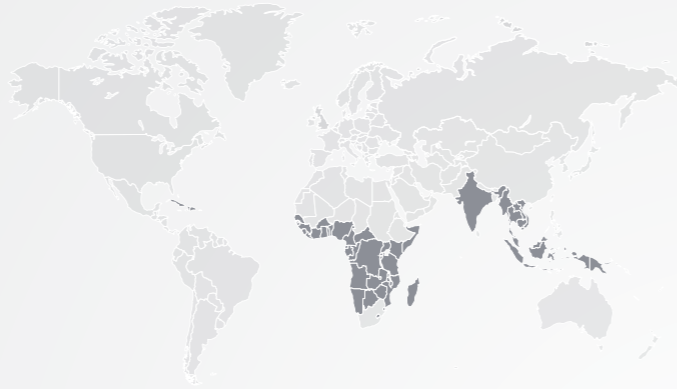

Model number	KWSM-09R410ACF	KWSM-12R410ACF	KWSM-18R410ACF	KWSM-24R410ACF	
Power supply	220 - 240V / 1Ph / 50Hz				
Heat exchangers	Highly Anti-corrosive Coating on Heat Exchangers / Best efficiency option				
Capacity	Btu/h	9000	12000	18000	24000
Control type	Remote Controller (standard) & Smart App Controller compatible with all major A.I. voice assistants				
Refrigerant type	R410A Environmentally Friendly Refrigerant				
Compressor	Brand	GMCC		Hitachi	
Compressor	Frequency	Fixed			
Operation temperature	°C	-7 ~ 43		18 ~ 43	
Applicable area	m ²	9 ~ 12	12 ~ 19	20 ~ 35	30 ~ 50
Loading quantity 40'HQ	370		310	235	184

DC Inverter Wall Split Air Conditioner KP1



Model number	KWSM-09IR410ACF	KWSM-12IR410ACF	KWSM-18IR410ACF	KWSM-24IR410ACF	
Power supply	220 - 240V / 1Ph / 50Hz				
Heat exchangers	Highly Anti-corrosive Coating on Heat Exchangers / Best efficiency option				
Capacity	Btu/h	9000 (2047 ~ 9895)	12000 (2047 ~ 13310)	18000 (3412 ~ 19790)	24000 (4095 ~ 25930)
Control type	Remote Controller (standard) & Smart App Controller compatible with all major A.I. voice assistants				
Refrigerant type	R410A Environmentally Friendly Refrigerant				
Compressor	Brand	GMCC		Sanyo	
Compressor	Frequency	DC Inverter Technology			
Operation temperature	°C	18 ~ 50			
Applicable area	m ²	9 ~ 16	15 ~ 23	20 ~ 35	30 ~ 50
Loading quantity 40'HQ	327		310	230	200

AEOLUS

AEOLUS
S E R I E S



Aeolus Story

In ancient Greek mythology, Aeolus was the keeper of the winds. He lived on the floating island of Aeolia and had complete control over the four winds of the earth - the north, south, east, and west winds.

Through his mastery over the winds, Aeolus played a pivotal role in helping the gods shape the weather and climate across Greece. Farmers and sailors alike prayed to Aeolus for favorable conditions.

Inspired by the mythical Aeolus, Kanion Co Aeolus Series air conditioners empower modern homeowners with unparalleled control over their indoor climate. Just as Aeolus commanded the winds no matter where they were coming from, Aeolus Series air conditioners can effortlessly cool or heat a house no matter its geographical location, whether it is in the far north with below zero temperatures or near the equator with very high temperatures almost throughout the year.

T3 Saudi Arabia Standard DC Inverter Wall Split Air Conditioner / Heat Pump KA3



Model number	KWSMT3-12IR410AHS	KWSMT3-18IR410AHS	KWSMT3-24IR410AHS	
Power supply	230V / 1Ph / 60Hz			
Heat exchangers	Highly Anti-corrosive Coating on Heat Exchangers / Best efficiency option			
Capacity	Btu/h	12000	18000	24000
Control type	Remote Controller (standard) & Smart App Controller compatible with all major A.I. voice assistants (optional)			
Refrigerant type	R410A Environmentally Friendly Refrigerant			
Compressor	Brand	GMCC	Sanyo	GMCC
	Frequency	DC Inverter Technology		
Loading quantity	20'GP / 40'GP / 40'HQ	96/199/230	60/120/157	55/120/143

T3 Saudi Arabia Standard Fixed Frequency Wall Split Air Conditioner / Heat Pump KA2

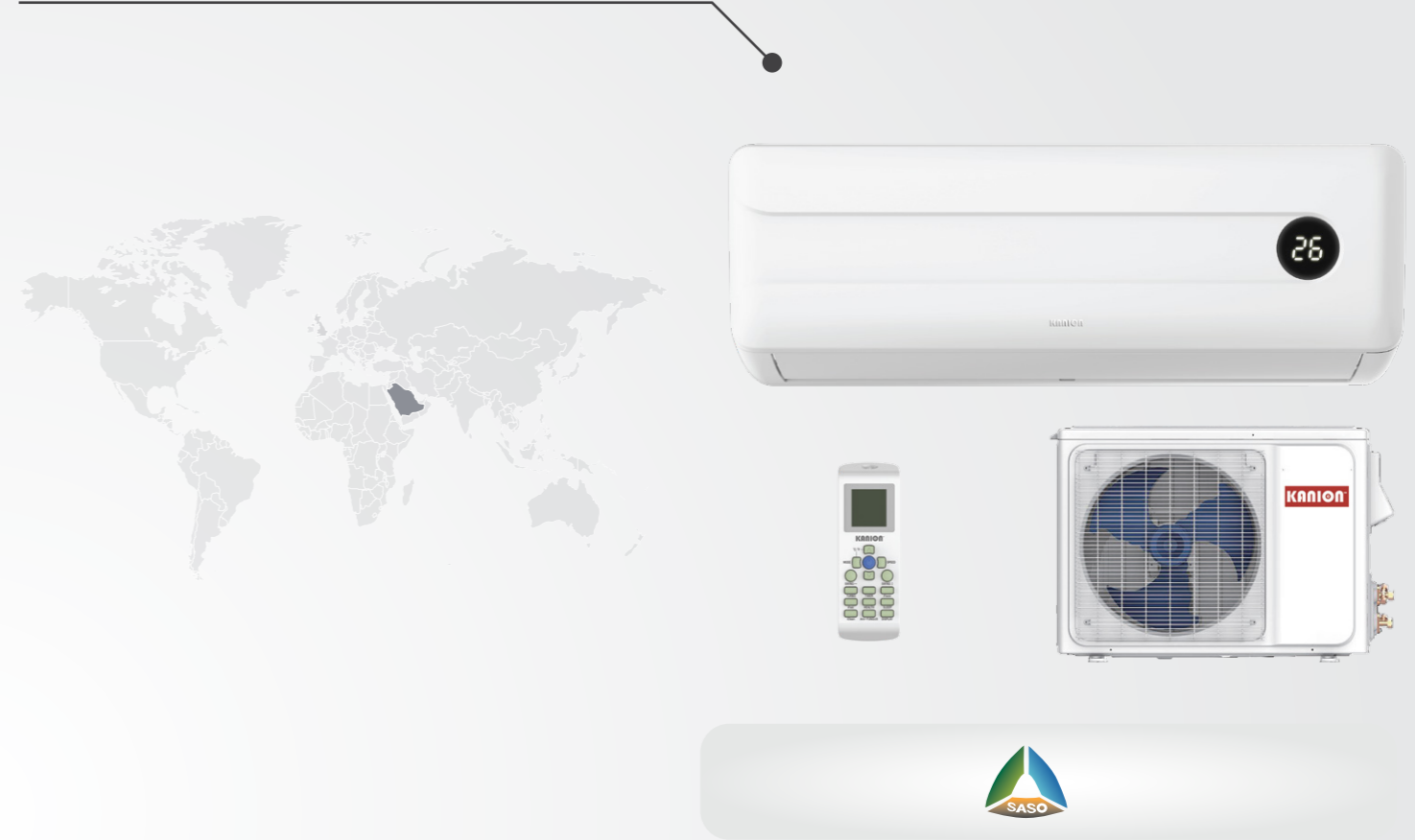

Model number	KWSMT3-12R410AHS	KWSMT3-18R410AHS	KWSMT3-24R410AHS	
Power supply	230V / 1Ph / 60Hz			
Heat exchangers	Highly Anti-corrosive Coating on Heat Exchangers / Best efficiency option			
Capacity	Btu/h	12000	18000	24000
Control type	Remote Controller (standard) & Smart App Controller compatible with all major A.I. voice assistants (optional)			
Refrigerant type	R410A Environmentally Friendly Refrigerant			
Compressor	Brand	GMCC	Highly	GMCC
	Frequency	Fixed		
Loading quantity	40'HQ	200	145	150

T3 Saudi Arabia Standard Fixed Frequency Wall Split Air Conditioner KA1

AEOLUS
SERIES



Model number	KWSMT3-12R410ACS	KWSMT3-18R410ACS	KWSMT3-24R410ACS	KWSMT3-30R410ACS	KWSMT3-36R410ACS	
Power supply	230V / 1Ph / 60Hz					
Heat exchangers	Highly Anti-corrosive Coating on Heat Exchangers / Best efficiency option					
Capacity	Btu/h	12000	18000	24000	30000	36000
Control type	Remote Controller (standard) & Smart App Controller compatible with all major A.I. voice assistants (optional)					
Refrigerant type	R410A Environmentally Friendly Refrigerant					
Compressor	Brand	GMCC	Highly	GMCC		
	Frequency	Fixed				
Loading quantity 40'HQ	227	147	144	111	100	

T3 Middle East Fixed Frequency Wall Split Air Conditioner KA1

AEOLUS
SERIES

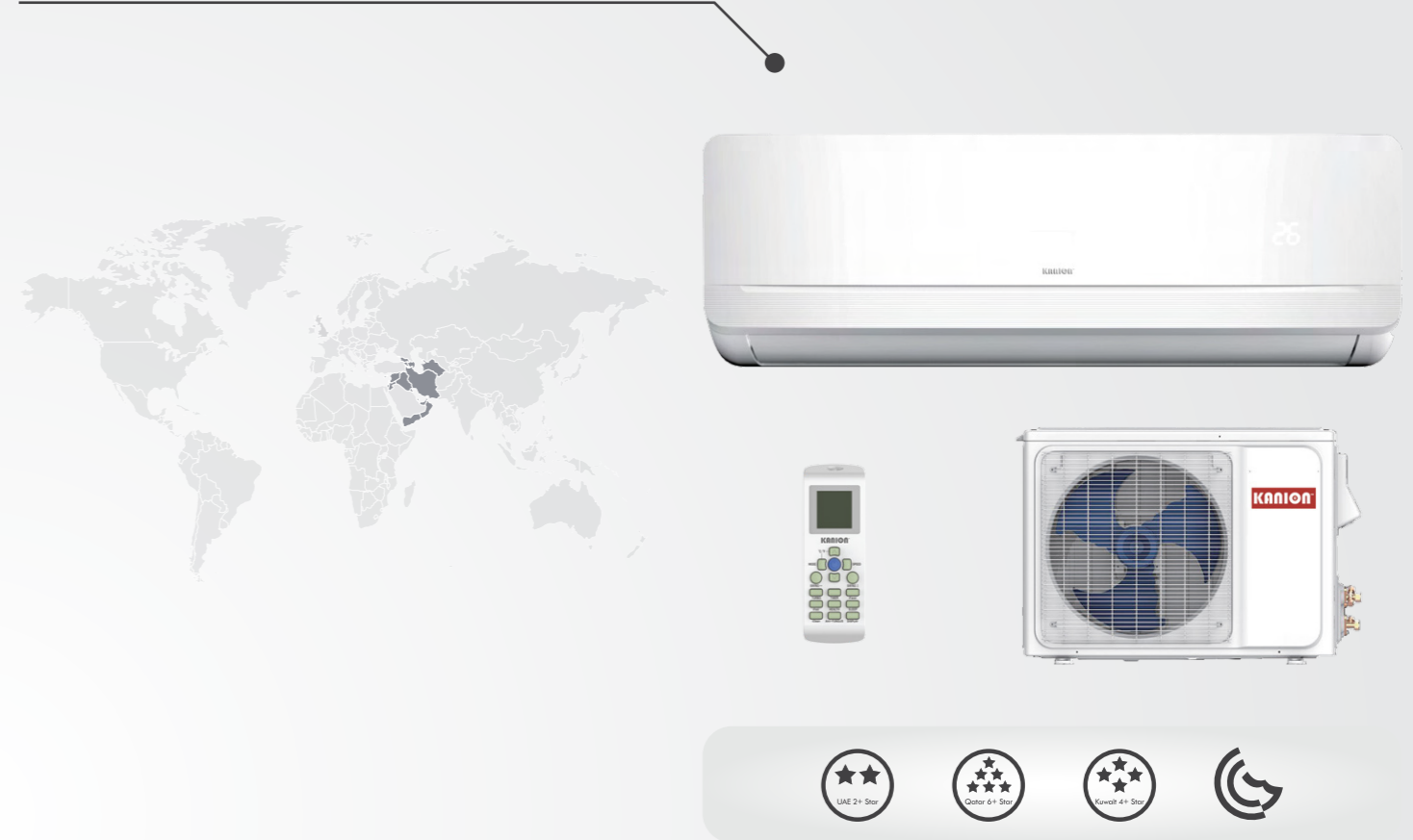

Model number	KWSMT3-12R410ACF	KWSMT3-18R410ACF	KWSMT3-24R410ACF	KWSMT3-30R410ACF	KWSMT3-36R410ACF	
Power supply	220 - 240V / 1Ph / 50Hz					
Heat exchangers	Highly Anti-corrosive Coating on Heat Exchangers / Best efficiency option					
Capacity	Btu/h	12000	18000	24000	30000	36000
Control type	Remote Controller (standard) & Smart App Controller compatible with all major A.I. voice assistants (optional)					
Refrigerant type	R410A Environmentally Friendly Refrigerant					
Compressor	Brand	Highly	GMCC			
	Frequency	Fixed				
Loading quantity 40'HQ	227	147	144	111	100	

Hybrid Solar T1 / T3 Dual Technology Air Conditioner / Heat Pump



100% Solar Off Grid DC48V Air Conditoner / Heat Pump



Model number			KWSM-12IR410AHSRH	KWSM-18IR410AHSRH	KWSM-24IR410AHSRH
Power supply	AC Power	Ph-V-Hz	1Ph 208V - 240V / 50 - 60HZ		
	DC Power (PV in Series)	V	80 - 380V		
	DC Power Current	A	< / = 10A		
Heat exchangers			Highly Anti-corrosive Coating on Heat Exchangers / Best efficiency option		
Advised solar panel		Pcs	(3 - 4) * 330W in series		(3 - 8) * 330W in series
Capacity	Cooling (T1)	W	3510 (900 - 3900)	5070 (1200 - 6000)	6450 (1800 - 7900)
		BTU	12000 (3000 - 13300)	17300 (4100 - 20400)	22000 (6100 - 27000)
	Cooling (T3)	W	2910	4290	5130
		BTU	9900	14700	17500
Control type			Remote Controller (standard) & Smart App Controller compatible with all major A.I. voice		
Refrigerant type			R410A environmentally friendly refrigerant		
Compressor	Brand		Highly		Panasonic
	Frequency		3D DC Inverter technology		
Applicable area		m ²	12 - 20	20 - 30	30 - 42
Loading quantity 20'GP / 40'HQ			85 / 200	75 / 160	50 / 115

Model number			KWSM-09IR410AHSRF	KWSM-12IR410AHSRF	KWSM-18IR410AHSRF	KWSM-24IR410AHSRF
Power supply			DC48V (46 - 58V)			
Heat exchangers			Highly Anti-corrosive Coating on Heat Exchangers / Best efficiency option			
Capacity	Cooling (T1)	W	2600 (1000 - 3400)	3510 (1000 - 3700)	5070 (1200 - 5250)	6450 (2500 - 7000)
		BTU	9000 (3400 - 11600)	12000 (3400 - 12600)	17300 (4100 - 18000)	22000 (8500 - 23900)
	Cooling (T3)	W	2490	2910	4200	5370
		BTU	8500	9900	14300	18300
Power input	Cooling (T1)	W	680 (180 - 1060)	980 (200 - 1200)	1450 (220 - 1780)	1840 (450 - 2230)
	Cooling (T3)	W	960	1090	1660	2200
Controller Type			Remote Controller (standard) & Smart App Controller compatible with all major A.I. voice assitants			
Compressor	Brand		GMCC		Highly	Panasonic
	Frequency		3D DC Inverter technology			
Applicable area		m ²	8-12	12-20	20-30	30-40
Loading quantity 20'GP / 40'HQ			85 / 200		75 / 160	50 / 115